



Cisco Unified Contact Center Express Solution Reference Network Design

Cisco Unified Contact Center Express, Release 7.0

June, 2009

Americas Headquarters

Cisco Systems, Inc.
170 West Tasman Drive
San Jose, CA 95134-1706
USA
<http://www.cisco.com>
Tel: 408 526-4000
800 553-NETS (6387)
Fax: 408 527-0883

THE SPECIFICATIONS AND INFORMATION REGARDING THE PRODUCTS IN THIS MANUAL ARE SUBJECT TO CHANGE WITHOUT NOTICE. ALL STATEMENTS, INFORMATION, AND RECOMMENDATIONS IN THIS MANUAL ARE BELIEVED TO BE ACCURATE BUT ARE PRESENTED WITHOUT WARRANTY OF ANY KIND, EXPRESS OR IMPLIED. USERS MUST TAKE FULL RESPONSIBILITY FOR THEIR APPLICATION OF ANY PRODUCTS.

THE SOFTWARE LICENSE AND LIMITED WARRANTY FOR THE ACCOMPANYING PRODUCT ARE SET FORTH IN THE INFORMATION PACKET THAT SHIPPED WITH THE PRODUCT AND ARE INCORPORATED HEREIN BY THIS REFERENCE. IF YOU ARE UNABLE TO LOCATE THE SOFTWARE LICENSE OR LIMITED WARRANTY, CONTACT YOUR CISCO REPRESENTATIVE FOR A COPY.

The Cisco implementation of TCP header compression is an adaptation of a program developed by the University of California, Berkeley (UCB) as part of UCB's public domain version of the UNIX operating system. All rights reserved. Copyright © 1981, Regents of the University of California.

NOTWITHSTANDING ANY OTHER WARRANTY HEREIN, ALL DOCUMENT FILES AND SOFTWARE OF THESE SUPPLIERS ARE PROVIDED "AS IS" WITH ALL FAULTS. CISCO AND THE ABOVE-NAMED SUPPLIERS DISCLAIM ALL WARRANTIES, EXPRESSED OR IMPLIED, INCLUDING, WITHOUT LIMITATION, THOSE OF MERCHANTABILITY, FITNESS FOR A PARTICULAR PURPOSE AND NONINFRINGEMENT OR ARISING FROM A COURSE OF DEALING, USAGE, OR TRADE PRACTICE.

IN NO EVENT SHALL CISCO OR ITS SUPPLIERS BE LIABLE FOR ANY INDIRECT, SPECIAL, CONSEQUENTIAL, OR INCIDENTAL DAMAGES, INCLUDING, WITHOUT LIMITATION, LOST PROFITS OR LOSS OR DAMAGE TO DATA ARISING OUT OF THE USE OR INABILITY TO USE THIS MANUAL, EVEN IF CISCO OR ITS SUPPLIERS HAVE BEEN ADVISED OF THE POSSIBILITY OF SUCH DAMAGES.

CCDE, CCENT, Cisco Eos, Cisco Lumin, Cisco Nexus, Cisco StadiumVision, Cisco TelePresence, the Cisco logo, DCE, and Welcome to the Human Network are trademarks; Changing the Way We Work, Live, Play, and Learn and Cisco Store are service marks; and Access Registrar, Aironet, AsyncOS, Bringing the Meeting To You, Catalyst, CCDA, CCDP, CCIE, CCIP, CCNA, CCNP, CCSP, CCVP, Cisco, the Cisco Certified Internetwork Expert logo, Cisco IOS, Cisco Press, Cisco Systems, Cisco Systems Capital, the Cisco Systems logo, Cisco Unity, Collaboration Without Limitation, EtherFast, EtherSwitch, Event Center, Fast Step, Follow Me Browsing, FormShare, GigaDrive, HomeLink, Internet Quotient, IOS, iPhone, iQ Expertise, the iQ logo, iQ Net Readiness Scorecard, iQuick Study, IronPort, the IronPort logo, LightStream, Linksys, MediaTone, MeetingPlace, MeetingPlace Chime Sound, MGX, Networkers, Networking Academy, Network Registrar, PCNow, PIX, PowerPanels, ProConnect, ScriptShare, SenderBase, SMARTnet, Spectrum Expert, StackWise, The Fastest Way to Increase Your Internet Quotient, TransPath, WebEx, and the WebEx logo are registered trademarks of Cisco Systems, Inc. and/or its affiliates in the United States and certain other countries.

All other trademarks mentioned in this document or Website are the property of their respective owners. The use of the word partner does not imply a partnership relationship between Cisco and any other company. (0807R)

Cisco Unified Contact Center Express Solution Reference Network Design
Copyright © 2008 Cisco Systems, Inc. All rights reserved.



CONTENTS

Preface i

Purpose	i
Audience	i
Scope	i
Software Releases	ii
Document Structure	ii
Obtaining Documentation, Obtaining Support, and Security Guidelines	iii
Documentation Feedback	iii

CHAPTER 1

Cisco Unified Contact Center Express Overview and Packaging 1-1

Cisco Unified CCX Overview	1-2
Cisco Unified CCX Packaging	1-3
Inbound Voice	1-4
IVR Ports	1-5
Inbound Voice Packaged Components	1-6
Automatic Call Distribution (ACD)	1-6
Interactive Voice Response (IVR)	1-9
Computer Telephony Integration (CTI)	1-12
Historical Reporting	1-12
Cisco Desktop Services (CAD, IPPA, CSD)	1-13
Cisco Unified CCX Outbound Preview Dialer	1-21
Cisco Unified Email Interaction Manager	1-22
Cisco Unified Web Interaction Manager	1-23
Quality Management	1-24
Workforce Management	1-26

CHAPTER 2

Cisco Unified Contact Center Express Solution Architecture for Cisco Unified Communications Manager 2-1

Cisco Unified CCX Terminology	2-2
Cisco Unified CCX Call Processing	2-4
Cisco Unified CCX System Management	2-5
Cisco Unified CCX Engine and Database Components	2-6
Monitoring and Recording Components	2-6

- Cisco Unified Wireless IP Phone 7920 IP Phone Support 2-9
- SIP Support 2-10
- Citrix Terminal Services Support for Cisco Agent Desktop 2-10
- Remote Agent Over Broadband 2-11
- Cisco TelePresence Virtual Agent Solution 2-11
- Cisco Unified CCX Outbound Preview Dialer 2-13
 - High Level Components 2-13
 - Functional Description 2-14
 - Behavior under High Availability 2-14
 - Scalability 2-15
 - Call Flow Description—Direct Preview Mode 2-15
 - Deployment Guidelines 2-16
- Cisco Interaction Manager 2-16
- Cisco Unified CCX Agent E-Mail 2-17
- Cisco Agent Desktop Integration with Cisco Unified Presence 2-20
- Agent Phones in Countries with Toll-Bypass Regulations 2-22
- Cisco Unified Workforce Optimization 2-22
- Cisco Unified CCX ASR and TTS 2-23
- Cisco Unified CCX Integration with Unified ICME Software 2-24
- Cisco Unified CCX Fault Tolerance 2-27
 - Cisco Unified CCX Engine Redundancy 2-27
 - Database Redundancy 2-28
 - Network Partitioning 2-29
 - Monitoring and Recording Redundancy 2-29
 - Cold Standby Support 2-30
 - Upgrading to Cisco Unified CCX 7.0 2-31
- Cisco Unified CCX 7.0 Software Compatibility 2-31

CHAPTER 3

Cisco Unified Contact Center Express Solution Architecture for Cisco Unified Communications Manager Express 3-1

- Architectural Overview 3-2
- Cisco Unified CCX Call Processing 3-3
- Cisco Unified CCX Engine and Database Components 3-4
 - Monitoring and Recording Components 3-4
- Cisco Unified CCX Fault Tolerance 3-5
 - Cold Standby Server 3-5
 - Basic ACD 3-5

CHAPTER 4**Cisco Unified Contact Center Express Deployment Models 4-1**

Cisco Unified CCX General Rules for Design 4-5

Single-Server Non-High Availability Deployment Model—Cisco Unified Communications Manager Integration 4-6

Two-Server High Availability Deployment Model—Cisco Unified Communications Manager Integration 4-6

Single-Server Non-High Availability Deployment Model—Cisco Unified Communications Manager Express Integration 4-7

Other Design Considerations 4-8

Multiple Cisco Unified CCX Clusters Integrated with a Single Cisco Unified Communications Manager Cluster 4-10

CHAPTER 5**Basics of Call Center Sizing 5-1**

Terminology 5-1

Preliminary Information Requirements 5-2

Principal Design Considerations for Call Center Sizing 5-4

Planning Resource Requirements for Call Center Sizing 5-5

CHAPTER 6**Sizing Cisco Unified Contact Center Express and Cisco Unified Communications Manager Servers 6-1**

Cisco A2Q Bid Assurance Requirements 6-1

Sizing Tools 6-1

Affect of Performance Criteria on the Cisco Unified CCX Server 6-2

Effect of Performance Criteria 6-2

Impact of Performance Criteria on the Cisco Unified CM Server(s) 6-3

CHAPTER 7**Bandwidth, Security, and QoS Considerations 7-1**

Estimating Bandwidth Consumption 7-1

Remote Agent Traffic Profile 7-1

Silent Monitoring Bandwidth Usage 7-2

Silent Monitoring Requestors 7-2

Silent Monitoring Providers 7-2

IP Call Bandwidth Usage 7-4

Bandwidth Requirements for VoIP Monitor Service 7-6

CAD Desktop Applications Bandwidth Usage 7-7

Cisco Agent Desktop Bandwidth Usage 7-8

Cisco Supervisor Desktop Bandwidth Usage 7-9

Cisco Desktop Administrator Bandwidth Usage 7-10

- Remote Agent Traffic Profile 7-10
- Serviceability and Security 7-11
 - Corporate Data Access 7-11
 - Port Utilization for Product Revisions 7-12
 - Ping, NAT, PAT, and Reverse DNS Lookups 7-12
- QoS and Call Admission Control 7-13
 - Classifying Cisco Unified CCX and Application-Related Traffic 7-13
 - QoS Considerations for CAD software 7-14
- CAC and RSVP 7-14

APPENDIX A

Server Capacities and Limits A-1

APPENDIX B

Voice Over IP Monitoring B-1

- Design Considerations for SPAN-Based Services B-1
- Deployment Guidelines for Agent Phones that support G.722 or iLBC B-3

APPENDIX C

Cisco Unified Contact Center Express Integration with LDAP Server C-1

INDEX



Preface

Purpose

This document provides system-level best practices and design guidance for the Cisco Unified Contact Center Express (Cisco Unified CCX), Release 7.0. With proper planning, design, and implementation, Cisco Unified CCX provides a reliable and flexible voice processing and contact center solution for the enterprise.

Audience

This design guide is intended for the system architects, designers, engineers, and Cisco channel partners who want to apply best design practices for Cisco Unified CCX.

This design guide assumes that the reader is already familiar with the following concepts:

- Cisco Unified Communications Manager (Unified CM) Administration
- Cisco Unified CCX and Cisco Unified IP IVR administration
- General system requirements and network design guidelines available from your local Cisco Systems Engineer (SE)

Scope

This document describes the various components used to build a Cisco Unified CCX system, and it gives recommendations on how to combine those components into an effective solution for your enterprise.

The following topics are *not* covered in this design guide:

- Installation and configuration of Cisco Unified CCX, Unified IP IVR, and Agent Desktop. For more information about these Cisco products, refer to the online product documentation available at Cisco.com.
- Cisco Unified IP IVR programming guidelines. Cisco Unified CCX is a packaged solution built upon a Cisco software platform called Customer Response Solutions (CRS). The CRS platform supports Unified IP IVR solution package. Unified IP IVR can be used with Cisco Unified Contact Center Enterprise (Unified CCE). Unlike Cisco Unified CCX, the Unified IP IVR solutions do not provide ACD and CTI functions. In Unified CCE deployments, the ACD and CTI functions are

provided by the Cisco Unified Intelligent Contact Management Enterprise (Unified ICME) software. Unified ICME software, combined with Unified IP IVR and Cisco Communications Manager (Unified CM), make up the Unified CCE Solution.

- Best practices for Contact Service Queues (CSQs) and priority queuing of Cisco Unified CCX.
- Design guidelines for Cisco Unified Communications common infrastructure and call processing. For information on Cisco IP Telephony design, refer to the *Cisco IP Telephony Solution Reference Network Design* documentation available online at <http://www.cisco.com/go/designzone>.
- Cisco Unified CCX Voice Browser (using VoiceXML), automatic speech recognition (ASR), and text-to-speech (TTS) best practices. For specific information on these topics, refer to the Nuance Communications Inc. website at <http://www.nuance.com> or the IBM Websphere Voice server web page at http://www-306.ibm.com/software/pervasive/voice_server/
- The call sizing guidelines in this document are intended only to illustrate concepts in providing high-level sizing of call center resources. This document is not intended to be an all-inclusive guide to designing and sizing contact centers. Each deployment will be different and specific to your system requirements.

Software Releases

Unless stated otherwise, the information in this document applies specifically to Cisco Unified CCX Release 7.0. Software releases are subject to change without notice, and those changes may or may not be indicated in this document. Refer to the Cisco Unified CCX release notes for the latest software releases and product compatibility information.

Document Structure

This guide contains the following chapters and appendices:

- [Chapter 1, “Cisco Unified Contact Center Express Overview and Packaging”](#) provides an overview of the Cisco Unified CCX software and describes the Cisco Unified CCX packaging.
- [Chapter 2, “Cisco Unified Contact Center Express Solution Architecture for Cisco Unified Communications Manager”](#) describes the terminology, call processing, system management, Cisco Unified CCX Engine and Database components, Monitoring and Recording components, ASR and TTS, integration with Unified ICME, fault tolerance, and software compatibility for Cisco Unified CCX.
- [Chapter 3, “Cisco Unified Contact Center Express Solution Architecture for Cisco Unified Communications Manager Express”](#) provides an overview of the architecture for a Cisco Unified CCX deployment with Cisco Unified Communications Manager Express.
- [Chapter 4, “Cisco Unified Contact Center Express Deployment Models”](#) describes the way Cisco Unified CCX can be deployed.
- [Chapter 5, “Basics of Call Center Sizing,”](#) introduces the basic concepts involved in call center sizing.

- [Chapter 6, “Sizing Cisco Unified Contact Center Express and Cisco Unified Communications Manager Servers,”](#) discusses the impact of performance criteria on the Cisco Unified CCX and Unified CM servers.
- [Chapter 7, “Bandwidth, Security, and QoS Considerations,”](#) discusses estimating bandwidth consumption, serviceability and security, and quality of service and call admission control.
- [Appendix A, “Server Capacities and Limits”](#) provides a list of server capacities and limits.
- [Appendix B, “Voice Over IP Monitoring”](#) provides design considerations for SPAN-based services.
- [Appendix C, “Cisco Unified Contact Center Express Integration with LDAP Server”](#) provides information about directory services.
- The Index helps you find information in this guide.

Obtaining Documentation, Obtaining Support, and Security Guidelines

For information on obtaining documentation, obtaining support, security guidelines, and also recommended aliases and general Cisco documents, see the monthly *What’s New in Cisco Product Documentation*, which also lists all new and revised Cisco technical documentation, at:

<http://www.cisco.com/en/US/docs/general/whatsnew/whatsnew.html>

Documentation Feedback

You can provide comments about this document by sending email to the following address:

ccbu_docfeedback@cisco.com

We appreciate your comments.





CHAPTER 1

Cisco Unified Contact Center Express Overview and Packaging

This chapter describes the basic architecture and capabilities of Cisco Unified Contact Center Express (Cisco Unified CCX), release 7.0, and explains how to match those capabilities to your system requirements. This chapter contains the following sections:

- [Cisco Unified CCX Overview, page 1-2](#)
- [Cisco Unified CCX Packaging, page 1-3](#)
- [Inbound Voice, page 1-4](#)
- [Cisco Unified CCX Outbound Preview Dialer, page 1-21](#)
- [Cisco Unified Email Interaction Manager, page 1-22](#)
- [Cisco Unified Web Interaction Manager, page 1-23](#)
- [Quality Management, page 1-24](#)
- [Workforce Management, page 1-26](#)

Cisco Unified CCX 7.0 can be deployed with Cisco Unified Communications Manager (Cisco Unified CM) 7.x (Linux based appliance) or their corresponding Cisco Unified Communications Manager Business Edition (CUCMBE) or with Cisco Unified Communications Manager Express (Cisco Unified CME) 7.x. Cisco Unified CCX 7.0 is Windows 2003 based. These applications were formerly named Cisco CallManager and Cisco CallManager Express.

A complete list of Cisco Unified CM and Cisco Unified CME releases supported with each Cisco Unified CCX release is provided in the Cisco Unified CCX Software & Hardware Compatibility Guide, available at: http://www.cisco.com/en/US/products/sw/custcosw/ps1846/products_device_support_tables_list.html

This document addresses only the capabilities and deployment models of Cisco Unified CCX 7.0. For similar information about other releases of Cisco Unified CCX, refer the appropriate SRND for the release.



Note

Cisco Unified CCX 7.0 does not support expansion server for either non-high availability or high availability inbound deployments. In addition, because Cisco Unified CCX 7.0 operates on a Windows server and its compatible Cisco Unified CM(s) operate on a Linux server, co-resident deployments are not supported. High availability is supported only for the inbound voice option.

Cisco Unified CCX does not support Cisco Unified SRST or Cisco Unified CME running in SRST mode.

Cisco Unified CCX 5.0(2) and later releases support the deployment of Cisco Unified CME running on UC500.

Cisco Unified CCX Overview

Cisco Unified CCX 7.0 provides options to address multiple contact center functional areas using a variety of server deployment models. These functions and their associated deployment models are:

- Inbound voice is deployed on a one server non-high availability or a two server high availability cluster.
- Outbound voice does not support high availability but is deployed on the same servers as inbound voice.
- Multichannel capabilities are provided with Cisco Unified CCX only in the Premium package. Email is available through purchase of the Cisco Unified E-Mail Interaction Manager (Cisco Unified EIM) option. Chat and web collaboration are available through purchase of the Cisco Unified Web Interaction Manager (Cisco Unified WIM) option.
 - Cisco Unified EIM must be deployed on a separate dedicated server or cluster of servers. Cisco Unified EIM and Cisco Unified WIM may be deployed on the same server or cluster of servers as long as both are either the Basic package or both are the Advanced package.
 - Cisco Unified WIM must be deployed on a separate dedicated server or cluster of servers. Cisco Unified EIM and Cisco Unified WIM may be deployed on the same server or cluster of servers as long as both are either the Basic package or both are the Advanced package.

Note

EIM and WIM have been End-of-Life and will be End-of-Sale in August 2009.

- Cisco Quality Managers (QM) and Advanced Quality Managers (AQM) provide call and screen recording, respectively, as well as quality management and are additional cost options available only with Cisco Unified CCX Premium. QM and AQM must be deployed on a separate dedicated server.

Note

QM and AQM are different from the integrated on-demand recording capability available with both Cisco Unified CCX Enhanced and Premium. On-demand recording continues to run as an integrated feature on the Cisco Unified CCX active and/or standby servers.

- Cisco Workforce Manager (WFM) must be deployed on a separate dedicated single server.

Note

The specific deployment models and the server or multiple servers that are required for a deployment model can only be determined by using the Cisco Unified CCX 7.0 Configuration and Ordering Tool. This tool is required by the Cisco Assessment to Quality (A2Q) process for every new, add-on, and upgrade system. The tool is available at:

http://www.cisco.com/en/US/partner/products/sw/custcosw/ps1846/prod_how_to_order.html

The tool provides a structured way to configure a Cisco Unified CCX system, automatically pass or fail a configuration, and it provides a complete bill of materials for the configuration.

These options can be deployed on Cisco Media Convergence Servers (MCSs) or on HP or IBM MCS equivalents for any of the functional components with the supported deployment models. However, different functional components require different deployment models and high availability is available only for inbound voice. In addition, high availability for inbound voice, outbound, Email Interaction Manager, Web Interaction Manager, quality management, and workforce management are not supported for Cisco Unified CME. Different features require different deployment models.

Cisco Assessment to Quality (A2Q) requires that all deployments of Cisco Unified CCX 7.0 use the Cisco Unified CCX 7.0 Configuration and Ordering Tool to complete pass bid assurance. The Cisco Unified CCX 7.0 Configuration and Ordering Tool provides a complete list of all the servers and server configurations required for a given Cisco Unified CCX 7.0 deployment.

Cisco Unified CCX Packaging

Cisco Unified CCX is a complete customer interaction management solution available in three different packages: Standard, Enhanced and Premium. Different packages provide varying levels of customer interaction management channel options and capability within a contact channel. [Table 1-1](#) and [Table 1-2](#) describe the major customer interaction management options and their availability. For more detailed information, refer product data sheets, feature guides and end user documentation for each type of Cisco Unified CCX customer contact interaction management at the following URL:

<http://www.cisco.com/en/US/partner/products/sw/custcosw/ps1846/index.html>

Cisco Unified CCX deployments must have all product components and optional features of the same package type. Mixing components or options from different packages is not supported. For example, Enhanced Inbound voice agents and Premium Basic Email Interaction Manager agents is not supported.

Table 1-1 *Customer Interaction Channel Availability by Cisco Unified CCX Package for Cisco Unified CM*

Contact Channel	Premium	Enhanced	Standard
Inbound Voice	Yes	Yes	Yes
Inbound Voice High Availability	Yes	Yes	No
Cisco Unified CCX Outbound Preview Dialer	Yes	No	No
Basic or Advanced Email Interaction Manager	Yes	No	No
Basic or Advanced Web Interaction Manager	Yes	No	No
Quality Manager	Yes	No	No
Workforce Manager	Yes	No	No

Table 1-2 *Customer Interaction Channel Availability for Cisco Unified CM and Cisco Unified CME*

Contact Channel	Cisco Unified CM	Cisco Unified CME
Inbound Voice	Yes	Yes
Inbound Voice High Availability	Yes	No
Cisco Unified CCX Outbound Preview Dialer	Yes	No
Basic or Advanced Email Interaction Manager	Yes	No
Basic or Advanced Web Interaction Manager	Yes	No
Quality Manager	Yes	No
Workforce Manager	Yes	No

**Note**

Starting from Cisco Unified CCX 5.0(2), the standard package will support skill and competency-based routing. However, it will no longer support Cisco Agent Desktop. IP Phone Agent and Cisco Supervisor Desktop will continue to be supported. For deployment of Cisco Unified CME on UC500, Cisco Unified CCX supports only the Standard package.

Inbound Voice

Cisco Unified CCX Standard, Enhanced and Premium each provide varying levels of inbound voice ACD, IVR, CTI, agent and supervisor desktops and desktop administration, real-time and historical reporting, and web based administration features.

For a comparison of feature content by package, refer the Cisco Contact Center Express 7.0 Features and Specifications reference document at:

http://www.cisco.com/en/US/partner/products/sw/custcosw/ps1846/products_data_sheets_list.html

Each user license is for a concurrent user. For example, a contact center with three shifts of 100 agents and supervisors requires 100 concurrent user licenses. Each shift of 100 users would reuse these licenses during their shifts.

Table 1-3 lists the inbound voice licensed components.

Table 1-3 Inbound Voice Licensed Components

License	Premium	Enhanced	Standard
<p>Concurrent inbound voice seat.</p> <p>Each concurrent inbound voice user (agent or supervisor) requires a concurrent seat license. Each quantity one seat license provides:</p> <ul style="list-style-type: none"> Quantity one Cisco Agent Desktop (CAD) Quantity one Cisco IP Phone Agent (IPPA) Quantity one Cisco Supervisor Desktop (CSD) Quantity one Cisco Desktop Administrator (CDA) Quantity one historical reporting client Quantity one on demand recording client (CAD and CSD) <p>Note In Cisco Unified CCX 5.0(2) and later releases, CAD is available only for Enhanced and Premium packages.</p>	<p>Yes.</p> <p>Note On demand recording only available in Enhanced and Premium.</p>	<p>Yes.</p> <p>Note On demand recording only available in Enhanced and Premium.</p>	<p>Yes.</p> <p>Note On demand recording not available in Standard.</p>
<p>Advanced IVR port.</p> <p>Note For more detailed information, see the “IVR Ports” section on page 1-5.</p>	<p>Yes.</p> <p>Note Quantity two Advanced IVR Ports per each quantity one Premium Inbound Voice seat.</p>	Not available.	Not available.
<p>High Availability (HA) option.</p> <p>HA provides licensing for mirrored, warm standby server software.</p>	Yes.	Yes.	Not available.

IVR Ports

IVR ports are packaged as either Basic or Advanced IVR ports.

- Basic IVR Ports Licensing—Basic IVR ports are not licensed and a given configuration may have as many Basic IVR ports as fit given the server on which the system is deployed and the mix of other features deployed on that server. You must use the Cisco Unified CCX Configuration and Ordering Tool to determine the maximum number of Basic IVR ports that are supported on a per configuration basis. Basic IVR ports provide a queue point, custom messaging and prompting, caller input collection, and processing via DTMF decoding. Decoded DTMF input may be used for both routing and screen pop purposes. Basic IVR ports (and only Basic IVR ports) are available in both the Standard and Enhanced packages.

- **Advanced IVR ports licensing**— Advanced IVR ports are licensed on a per inbound voice seat basis and are available only with the Premium package. Each inbound voice seat provides two Advanced IVR port licenses. For example, a 100 seat inbound voice deployment provides 200 Advanced IVR port licenses. Advanced IVR port licenses counts are checked at run-time. In the example given here, the 201st simultaneously active request for an Advanced IVR port to handle an incoming call would be denied. Deployments requiring more IVR ports than provided by this 1:2 seat:Advanced IVR port ratio would need to purchase one additional Premium inbound voice seat for each two additional Advanced IVR ports required.

Inbound Voice Packaged Components

The primary components provided with inbound voice are described in the following sections. These sections provide high level descriptions of the features and functions provided for these components. For more specific information, refer the Cisco Unified CCX user documentation.

- [Automatic Call Distribution \(ACD\)](#), page 1-6
- [Interactive Voice Response \(IVR\)](#), page 1-9
- [Computer Telephony Integration \(CTI\)](#), page 1-12
- [Cisco Desktop Services \(CAD, IPPA, CSD\)](#), page 1-13
- [Historical Reporting](#), page 1-12

Automatic Call Distribution (ACD)

Table 1-4 describes the Automatic Call Distribution (ACD) features that are available in each Cisco Unified CCX Package.

Table 1-4 ACD Features Available in Each Cisco Unified CCX Package

Feature	Premium	Enhanced	Standard
Conditional Routing. Cisco Unified CCX supports routing based upon caller input to menus, real-time queue statistics, time of day, day of week, ANI, dialed number, and processing of data from XML text files.	Included.	Included.	Included.
Agent Selection. Cisco Unified CCX supports longest available, linear, most handled contacts, shortest average handle time, and circular agent selection algorithms. With Basic ACD functionality, agents are associated with one resource group only.	Included.	Included.	Included.
Customizable Queuing Announcements. Cisco Unified CCX supports the playing of customizable queuing announcements based upon the skill group that the call is being queued to, including announcements related to position in queue and expected delay.	Included.	Included.	Included.

Table 1-4 ACD Features Available in Each Cisco Unified CCX Package (continued)

Feature	Premium	Enhanced	Standard
Re-route on Ring No Answer. If the selected agent does not answer within the allowed time limit, the caller retains the position in queue. Any screen pop data is also preserved.	Included.	Included.	Included.
<p>Cisco Unified Intelligent Contact Management Enterprise (Cisco Unified ICME) Integration. Cisco Unified CCX can integrate with Cisco Unified ICME 7.x. Cisco Unified ICME integration provides the following capabilities:</p> <ul style="list-style-type: none"> • The ability for Cisco Unified CCX to send agent, queue, and call state changes to Cisco Unified ICME software • The ability of Cisco Unified ICME software to intelligently route and load balance (using pre-routing or post-routing) calls across multiple ACD sites, which can include one or more Cisco Unified CCX systems, Cisco Unified CCE systems, or traditional ACDs (that are supported by Cisco Unified ICME software). Calls routed to an Cisco Unified CCX application can also be sent call data so that the data can be popped onto an agent screen. • The ability for Cisco Unified CCX to send post-route requests with call data to the Cisco Unified ICME software to request routing instructions. This event could be in response to a new call that just arrived at Cisco Unified CCX or a call that is being transferred from an IVR port or agent. Call data included in the post-route request can be used by the Cisco Unified ICME software to profile route the call. Call data is also passed to the terminating ACD site (Cisco Unified CCX, Cisco Unified CCE, or traditional ACD) for an agent screen pop. • The ability for Cisco Unified ICME software to provide multi-site ACD reporting for a mixed network of ACD sites, which can include one or more Cisco Unified CCX systems, Cisco Unified CCE systems, or traditional ACDs. <p>Note Integration of Cisco Unified CCX with Cisco Unified ICME is supported for Cisco Unified Communications Manager, but not Cisco Unified Communications Manager Express.</p>	Optional.	Optional.	Optional.

Table 1-4 ACD Features Available in Each Cisco Unified CCX Package (continued)

Feature	Premium	Enhanced	Standard
Data driven routing for HTML and XML data sources. The ability to use data obtained from HTML or XML documents to make routing decisions. XML document processing can also be used as a data store to access system-wide static data like a list of holidays, hours of operations, a short list of hot customer accounts, and so on.	Included.	Included.	Included.
Agent Skill and Competency-Based Routing. Agents can be configured with up to 50 skills, each with up to 10 a different competency levels. Contact Service Queues (also known as skill groups) can be configured as requiring up to 50 skills, each with up to 10 minimum skill competency levels. The Cisco Unified CCX routing logic then matches the caller and contact requirements with agent skills to find the optimum match using one of the following agent selection criteria: <ul style="list-style-type: none"> • Longest available, most handled contacts, or shortest average handle time • Most skilled, most skilled by weight, or most skilled by order • Least skilled, least skilled by weight, or least skilled by order Note Starting with Cisco Unified CCX 5.0(2), this feature is available with the Standard package. It is not available with the standard package for releases prior to Cisco Unified CCX 5.0(2).	Included.	Included.	Included.
High Availability Failover. With HA failure of the active server can be detected and the ACD subsystem can automatically fail over from the active to the standby server. All ACD functions are restored on the standby server within 5 seconds.	Optional with HA license.	Optional with HA license.	Not available.
Dynamic Reskilling by Administrator or Supervisor. Changes to CSQ skills and competencies and agent skills and competencies are applied immediately.	Included.	Included.	Included.
Prioritized Queuing. Up to 10 levels of customer contacts can be prioritized based upon call or customer data, and calls may be moved within or among queues under workflow control using priority information.	Included.	Included.	Not available.

Table 1-4 ACD Features Available in Each Cisco Unified CCX Package (continued)

Feature	Premium	Enhanced	Standard
Agent Routing. Cisco Unified CCX routing applications can select a specific agent if that agent is in Ready state. (Queuing on a per agent basis is not supported.)	Included.	Included.	Not available.
Data driven routing based on ODBC database sources via SQL. The ability to use data obtained from an ODBC compatible database via a SQL query to make routing decisions	Included.	Not available.	Not available.
Wrap-up and work Modes. After call completion, an agent can be configured to be automatically placed into Work state, on a per CSQ basis. The agent can also choose to enter work state if that option is provided by the agent's desktop administrator. A wrap-up timer is also configurable on a per CSQ basis.	Included.	Included.	Not available.
Wrap Up Codes. Agents may select administratively defined wrap up codes.	Included.	Included.	Not available.

Interactive Voice Response (IVR)

Table 1-5 describes the Interactive Voice Response (IVR) features that are available in each Cisco Unified CCX Package.

Table 1-5 IVR Features Available in Each Cisco Unified CCX Package

Feature	Premium	Enhanced	Standard
Basic Prompt & Collect IVR. Basic IVR ports provide a queue point, custom messaging and prompting, caller input collection, and processing via DTMF decoding. Decoded DTMF input may be used for both routing and screen pop purposes. Basic call controls such as terminate, transfer, and place call are also supported as part of the basic IVR functionality. Note Basic IVR port and Advanced IVR port cannot be mixed in the same configuration. Advanced IVR port includes all features available in Basic IVR port.	Not available.	Included.	Included.
High Availability Failover. With HA, failure of the active server is can be detected and the IVR subsystem can automatically fail over from the active to the standby server. All IVR functions will be restored on the standby server within 5 seconds. Note All calls in queue and calls receiving IVR call treatment will be lost. Calls already transferred to the agent will be preserved.	Optional with HA license.	Optional with HA license.	Not available.

Table 1-5 *IVR Features Available in Each Cisco Unified CCX Package (continued)*

Feature	Premium	Enhanced	Standard
<p>Advanced IVR Port Database Integration. The Cisco Unified CCX server can interoperate with any ODBC-compliant database. Databases tested and supported by Cisco are listed in <i>Cisco Unified CCX Software and Hardware Compatibility Guide</i>, which is available at:</p> <p>http://www.cisco.com/en/US/products/sw/custcosw/ps1846/products_device_support_tables_list.html</p> <p>Data retrieved from databases can be used with the conditional routing capabilities to provide customer profile-based routing and queuing. Database integration also provides the ability to offer complete self-service applications to callers. Database views are not supported using the Cisco Unified CCX Editor database steps, but database views could be accessed using Voice XML or Java logic modules.</p>	Included.	Not available.	Not available.
<p>Advanced IVR Ports HTTP Triggers (the web analogue to Cisco Unified CM Telephony) to invoke and run a workflow. HTTP triggers enable a Cisco Unified CCX to receive a customer contact request through an HTTP request. This approach allows web users to be offered service through a “click to talk to an agent” button. Information collected using the web (a customer call back number, account number, shopping cart content, and so on) can be passed to the Cisco Unified CCX script to allow customer profile-based routing and a data-rich screen pop. These contacts can be prioritized and routed using the same methods available to normal inbound voice callers.</p>	Included.	Not available.	Not available.
<p>Advanced IVR Port SMTP outbound mail subsystem that may be used at run time under workflow control to send an e-mail. Third-party paging or fax products that accept an incoming e-mail to invoke a page or fax service may use this subsystem to provide real-time paging and fax responses in addition to e-mail responses.</p>	Included.	Not available.	Not available.

Table 1-5 *IVR Features Available in Each Cisco Unified CCX Package (continued)*

Feature	Premium	Enhanced	Standard
Advanced IVR Port Voice XML 2.0 Support. Unified CCX supports executing application logic developed with the Voice XML (VXML) standard. VXML is required for certain complex grammar ASR and TTS interactions and is optional for a DTMF or simple ASR or TTS voice interaction service. VXML allows organizations to reuse application logic from other applications, such as a transaction server to a mainframe database.	Included.	Not available.	Not available.
Advanced IVR Port Call Recording. The Cisco Unified CCX server can record input from callers. This capability could be used to allow call center staff to remotely record new announcements or prompts.	Included.	Included.	Included.
Advanced IVR Port Java Support. The Cisco Unified CCX server can support logic defined using Java. Java support allows for logic from existing web and Java applications to be reused.	Included.	Not available.	Not available.
Advanced IVR Port Automatic Speech Recognition via MRCP. ASR provides the ability to use natural human speech to replace DTMF keypad presses as a way to interact with IVR applications.	Optional with purchase of compatible ASR product from Nuance or IBM.	Not available.	Not available.
Advanced IVR Port Text to Speech via MRCP. TTS provides the ability to use flat text files as input to a computer generated speech engine. TTS can replace pre-recorded human speech in IVR applications.	Optional with purchase of compatible TTS product from Nuance or IBM.	Not available.	Not available.
Advanced IVR Port Remote Silent Monitoring. Provides a mechanism for silent monitoring of calls using an IP phone or a PSTN phone. This form of silent monitoring does not require a CSD application to be running but does require a seat license for any supervisor engaged in remote silent monitoring. Remote silent monitoring also does not require any data network connectivity and is ideally suited for management of outsourced customers of a call center service provider. The agent is unaware when being monitored using remote silent monitoring.	Included.	Not available.	Not available.

Computer Telephony Integration (CTI)

Computer Telephony Integrative (CTI) refers to the ability to use data available from caller entered data, ACD, IVR or other data sources, to pop to the agent, to use to make routing decisions, or to use as a key to perform a data lookup (for example, via a database access prior to popping to the agent or to use in making routing decisions). CTI may also imply the ability to invoke a third-party application and to pass data to that application as part of the agent screen pop.

Table 1-6 describes the CTI features that are available in each Cisco Unified CCX Package.

Table 1-6 CTI Features Available in Each Cisco Unified CCX Package

Feature	Premium	Enhanced	Standard
<p>Basic CTI. Provides a customizable enterprise data window that is popped on the agent desktop upon call ringing. Data within the enterprise data window includes ANI, dialed number, and any caller input (account number, order number, case number, reason for calling, and so on), and details about how long the caller interacted with the IVR, how long the caller waited in queue, and how long the caller spent with all other agents if this was a transferred call.</p> <p>Note For Cisco Unified CCX 5.0(2) and later releases, CAD is not supported on the Standard package, and so, the enterprise data is only available on IP Phone Agent.</p>	Included.	Included.	Included.
<p>Advanced CTI. Advanced CTI functionality allows call data to be passed to other Windows-based desktop applications (for example, CRM applications) for an application screen pop on ringing. Passing data to other applications is performed through keystroke macros that are then associated with specific call events such as call ringing or call release. With keystroke macros and HTTP put/get commands, no programming is required to develop a screen pop application.</p>	Included. Premium package adds support for using data from supported databases using workflow-based SQL queries.	Included. Enhanced package adds support for using data from XML data sources. Database integration is not supported.	Not available.

Historical Reporting

Cisco Unified CCX Historical Reporting provides supervisors and administrators with information about call, agent, and CSQ activities. Users of the Historical Reports can perform the following functions:

- View, print, and save reports.
- Sort and filter reports.
- Send scheduled reports to a file or to a printer.
- Export reports in a variety of formats, including PDF, RTF, XML, and CSV.
- Prepare custom reports using a variety of generally available 3rd party applications that are designed to create reports from databases.

Table 1-6 describes the CTI features that are available in each Cisco Unified CCX Package.

Table 1-7 Historical Reporting Features Available in Each Cisco Unified CCX Package

Feature	Premium	Enhanced	Standard
Viewing Reports. View reports for the entire contact center using the Historical Reports client.	Included	Included	Included
Custom Reports. Generate custom reports using a combination of the Crystal Reports Developer's Toolkit and SQL stored procedures. For more information, refer the <i>Cisco Unified CCX Historical Reporting Administrator and Developer Guide</i> and <i>Cisco Unified CCX Database Schema</i> .	Included	Included	Included

Cisco Desktop Services (CAD, IPPA, CSD)

Cisco Desktop Services provide Cisco Agent Desktop and IP Phone Agent for agent use, and Cisco Supervisor Desktop for supervisor use.

Table 1-8 describes the Cisco Desktop Services features that are available in each Cisco Unified CCX Package.

Table 1-9 on page 1-18 describes the IP Phone Agent (IPPA) features that are available in each Cisco Unified CCX Package.

Table 1-10 on page 1-19 describes the Cisco Supervisor Desktop features that are available in each Cisco Unified CCX Package.



Note

CAD is not available in the Standard package starting from Cisco Unified CCX 5.0(2).

Table 1-8 Cisco Agent Desktop Features Available in Each Cisco Unified CCX Package

Feature	Premium	Enhanced
Agent State Control. From the agent desktop, agents log in, log out, and make themselves ready and not ready.	Included.	Included.
Call Control. From the agent desktop, agents answer, release, hold, retrieve, conference, and transfer calls. (Call control can also be performed from a Cisco Unified IP Phone.) For example, to answer a call, the agent can simply pickup the phone handset. The Cisco Unified CCX software ensures that the current call state for the phone and CAD application are kept in synch. Note Call control initiated from the agent desktop is available only with Cisco Unified CCX with Cisco Unified CM, not with Cisco Unified CCX with Cisco Unified CME.	Included.	Included.
Dynamic Regrouping. Change of agent association with a resource group is applied immediately.	Included.	Included.
Real-Time Statistics. Agents have access to real-time statistics for themselves and the queues to which they are associated. For example, from the agent desktop application, agents can see how many calls they have handled today and how many calls are currently in queue for their team.	Included.	Included.
Integrated Text Messaging. Agents can interact with their supervisor and other agents through text chat.	Included.	Included.
Reason Codes. Agents can be configured to enter reason codes for not ready and logout.	Included.	Included.
Basic CTI. Agent desktops provide an enterprise data window that is popped upon call ringing.	Included.	Included.

Table 1-8 Cisco Agent Desktop Features Available in Each Cisco Unified CCX Package

Feature	Premium	Enhanced
<p>Telephony Support. CAD can be deployed with select Cisco Unified IP Phone models, as described <i>Cisco Unified CCX Software and Hardware Compatibility Guide</i>. However, there are different features available on different phones.</p> <p>CAD also supports the agent using the Cisco IP Communicator soft phone application running on the same workstation with CAD.</p> <p>An agent ACD (Cisco Unified CCX) extension is valid only with a single line. An agent ACD extension must not be configured to forward on no answer to a voice messaging system or to any other termination point. Doing so might affect re-routing on ring-no-answer of a Cisco Unified CCX routed call to another agent or back to queue. Agents who need to be contacted directly or who need voice messages should have their phones configured with a second extension (and multiple lines if necessary).</p> <p>Cisco Unified CCX does not monitor or report on activity on the non-ACD extensions on a phone.</p> <p>Agents are associated with a specific Cisco Unified Communications Manager extension (directory number).</p>	Included.	Included.
<p>Hot Desking. Hot desking allows agents to log in using CAD and any Cisco Unified IP Phone that is registered with the same Cisco Unified Communications Manager cluster. Agents using CAD and Cisco IP Communicator can also use Extension Mobility. This capability allows multiple agents to use the same phone, but only one at a time. For example, different agents on different shifts may use the same workstation and phone.</p> <p>Extension Mobility brings a user specific phone profile (including configured extensions for that user) to the phone being logged in from. After logging into Cisco Unified Communications Manager with Extension Mobility, agents can log into Cisco Unified CCX using CAD.</p>	Included.	Included.
<p>Auto Update. When the CAD starts up, it checks to see if a new version of the CAD program is available and automatically performs an update on the agent workstation.</p>	Included.	Included.

Table 1-8 Cisco Agent Desktop Features Available in Each Cisco Unified CCX Package

Feature	Premium	Enhanced
Desktop Workflows. A wizard based interface allowing desktop events (such as ringing or going off hook) to have associated rules and rule actions that are invoked when the rule is met for that event.	Included.	Included.
Application Integration. CAD can be configured using desktop workflows to allow call data to be passed to other desktop applications (for example, CRM applications) for an application screen pop. Passing data to other applications is performed through keystroke macros or HTTP put/get commands that are then associated with specific call events such as call ringing. No programming is required to develop a screen pop. Application integration can also be done upon call release to pop open a wrap-up application on the agent workstation	Included.	Included.
Workflow Buttons. CAD can be configured to have pre-defined workflow buttons that execute specified programs and keystrokes. Workflow buttons aid agents in completing repetitive tasks quickly.	Included.	Included.
On-Demand Call Recording. CAD can be configured to allow clicking a single button to start and stop call recording. The call recording contains only the portion of the call that occurs after the start record button is clicked. There are limits to how many simultaneous call recording sessions can be performed. Capacity and configuration limits are defined in the Cisco Unified CCX 7.0 Configuration and Ordering Tool.	Included.	Included.
Complete Call Recording. CAD can be configured to automatically start and stop recording upon call answer and release. Conditions upon which calls are to be recorded are defined in an application script. There are limits to how many simultaneous call recording sessions can be performed.	Included.	Included.

Table 1-8 Cisco Agent Desktop Features Available in Each Cisco Unified CCX Package

Feature	Premium	Enhanced
<p>Automatic Failover. Upon failure of the active Cisco Unified CCX server, CAD will automatically re-login agents on the standby server, and the agent will be placed into a Not Ready state. Upon failure of the active Cisco Unified CCX server, active calls on agents phones will survive. However, the call duration and other information that is associated with the call in the historical reporting database may be affected. Historical reports generated for time periods in which a failover occurred will have missing or incorrect data. It will be called out in the report that a failover occurred.</p>	Optional with HA license.	Optional with HA license.
<p>Wrap up Codes. Agents can use the CAD to select from one of many predefined wrap up codes either during the call or while the agent is in Work state.</p>	Included.	Included.
<p>Cisco Unified EIM and Cisco Unified WIM. CAD includes browser-based handling of e-mail and chat contacts. Agents may use the integrated browser within the CAD for this feature. Chat contact handling includes the ability for the agent to push web pages to the customer.</p>	Optional with Cisco Unified EIM or Cisco Unified WIM license.	Not available.
<p>Agent E-mail. This feature is tightly integrated into the agent desktop, with controls built into the toolbar and display. It queues and routes e-mails to staffed and skilled agents, facilitates the creation of the agent's response, and provides a collection of real-time and historical reports that help measure e-mail performance accurately.</p>	Included.	Not available.
<p>Presence. When integrated with Cisco Unified Presence, Agents and Supervisors can view the presence state of Subject Matter Experts (SMEs) on CAD and chat with them.</p>	Included.	Included.

Table 1-8 Cisco Agent Desktop Features Available in Each Cisco Unified CCX Package

Feature	Premium	Enhanced
Workforce Management. Workforce Management is a workforce scheduling solution in which the supervisor or any contact center manager can schedule their agents based on forecasted call volume and agent expertise, availability, and other factors. Agents have an interface for that portion of the Workforce Management application that applies to them	Optional with Workforce Management user license.	Not available.
Outbound. CAD includes buttons to control an agent response to an outbound contact offering by the system. If the agent clicks the Accept button, the system places the outbound call to the customer from the agent phone. Note The Outbound Dialer feature is only available with Cisco Unified CCX with Cisco Unified CM, not with Cisco Unified CCX with Cisco Unified CME.	Optional with Outbound license.	Not available.

Table 1-9 IPPA Features Available in Each Cisco Unified CCX Package

Feature	Premium	Enhanced	Standard
Agent State Control. From the IPPA XML application, agents log in, log out, and make themselves ready or not ready.	Included.	Included.	Included.
Call Control. The Cisco Unified IP Phone provides call control.	Included.	Included.	Included.
Dynamic Regrouping. Change of agent association with a resource group is applied immediately.	Included.	Included.	Included.
Real-Time Statistics. Agents have access to real-time statistics for themselves and the queues to which they are associated.	Included.	Included.	Included.
Reason Codes. Agents can be configured to enter reason codes for not ready and logout.	Included.	Included.	Included.
Basic CTI. IPPA allows for call data to be popped onto the IP Phone display upon call ringing	Included.	Included.	Included.
Telephony Support. IPPA can be run from any phone that supports an XML client.	Included.	Included.	Included.

Table 1-9 *IPPA Features Available in Each Cisco Unified CCX Package (continued)*

Feature	Premium	Enhanced	Standard
<p>Hot Desking. Hot desking allows agents to log in using IPPA and any Cisco Unified IP Phone that is registered with the same Cisco Unified Communications Manager cluster. Agents using IPPA and Cisco IP Communicator can also use Extension Mobility. This capability allows multiple agents to use the same phone, but only one at a time. For example, different agents on different shifts may use the same workstation and phone.</p> <p>Extension Mobility brings a user specific phone profile (including configured extensions for that user) to the phone being logged in from. After logging into Cisco Unified Communications Manager with Extension Mobility, agents can log into Cisco Unified CCX using CAD.</p>	Included.	Included.	Included.
<p>On-Demand Call Recording. IPPA can be configured to allow clicking a single button to start and stop call recording on demand. The call recording contains only the portion of the call that occurs after the start record button is clicked. There are limits to how many simultaneous call recording sessions can be performed. Capacity and configuration limits are defined in the Cisco Unified CCX 7.0 Configuration and Ordering Tool.</p>	Included.	Included.	Not available.

Table 1-10 *Cisco Supervisor Desktop Features Available in Each Cisco Unified CCX Package*

Feature	Premium	Enhanced	Standard
<p>View / Change Agent State. Supervisor desktops allow supervisors to view the current state of all agents that are part of that supervisor's team. The supervisor desktop also allows supervisors to change an agent state (Ready, Not Ready, Logout).</p>	Included.	Included.	Included.
<p>Real-Time Agent and Skill Statistics. Supervisors can view statistics for all agents and queues that are associated with their team. Refer the <i>Cisco Supervisor Desktop User's Guide</i> for more details about statistics available through the CSD application.</p>	Included.	Included.	Included.
<p>Integrated Text Messaging. Supervisors can send text messages to one or more agents.</p>	Included.	Included.	Included.
<p>Marquee Messages. Supervisors can send a scrolling marquee (broadcast) message to all agents on their team.</p>	Included.	Included.	Included.

Table 1-10 Cisco Supervisor Desktop Features Available in Each Cisco Unified CCX Package

Feature	Premium	Enhanced	Standard
Silent Monitoring. CSD allows a supervisor to silently monitor agent calls. Agents can be configured to be aware or unaware that they are being monitored.	Included.	Included.	Not available.
Barge-in. CSD allows a supervisor to barge in on an agent call. The barge-in feature enters the supervisor, the agent, and the caller into a three-way conference. This feature requires the supervisor to have the CAD application open and to be logged in as an agent. The agent is aware when the supervisor barges in. Barge-in is supported for agents using CAD with IP Communicator, CAD with IP Phone, or IPPA.	Included.	Included.	Not available.
Intercept. CSD allows a supervisor to intercept an agent call. The intercept feature transfers the call to the supervisor. This feature requires the supervisor to have the CAD application open and to be logged in as an agent. As the call releases from the agent desktop and phone, the agent is aware when an intercept occurs. The agent is then available to take another call. Intercept is supported for agents using CAD with IP Communicator, CAD with IP Phone, or IPPA.	Included.	Included.	Not available.
On-Demand Agent Call Recording. CSD allows a supervisor to dynamically start and stop recording agent calls on demand. Agents are not aware that they are being recorded. A call recording only contains the portion of the call that occurs after the start record button is clicked. There are limits to how many simultaneous call recording sessions can be performed. Capacity and configuration limits are defined in the Cisco Unified CCX 7.0 Configuration and Ordering Tool.	Included.	Included.	Not available.
Call Recording Playback and Exports. The CSD Record Viewer application allows a supervisor to play back calls that were recorded within the last 7 days. Supervisors can sort the recorded call list by agent, DN, or date/time. Within Record Viewer, supervisors can tag selected recordings for a 30-day extended archiving, and supervisors can save selected recordings as a .wav format in a specified folder for permanent archiving.	Included.	Included.	Not available.

Table 1-10 Cisco Supervisor Desktop Features Available in Each Cisco Unified CCX Package

Feature	Premium	Enhanced	Standard
Automatic Failover and Re-login. Upon Cisco Unified CCX Engine failover, the CSD automatically fails over to the standby Cisco Unified CCX Engine so the supervisor does not have to re-login.	Included.	Included.	Not available.
Workforce Management. Workforce Management is a workforce scheduling solution in which the supervisor or any contact center manager can schedule their agents based on forecasted call volume and the agents expertise, availability, and other factors.	Optional with Workforce Management user license.	Not available.	Not available.
Quality Management. Quality Management is a recording and quality management solution in which supervisors can choose to record all agent-customer calls, review the recordings, evaluate the agents, and suggest training classes accordingly	Optional with Quality Management license.	Not available.	Not available.

Cisco Unified CCX Outbound Preview Dialer

The Cisco Unified CCX Outbound Preview Dialer (Outbound) provides campaign based outbound preview dialer support. Each inbound Premium seat provides one outbound seat. This means that, if you have 100 inbound seats, you can have up to 100 agents logged in and up to 100 agents handling outbound calls at the same time.

[Table 1-11](#) lists the Outbound voice availability in each Cisco Unified CCX package.

Table 1-11 Outbound Voice Availability for Each Package

License	Premium	Enhanced	Standard
Outbound User.	Included.	Not available.	Not available.

[Table 1-12](#) describes the Outbound Voice features that are available in each Cisco Unified CCX Package.

Table 1-12 Outbound Voice Features Available in Each Cisco Unified CCX Package

Feature	Premium	Enhanced	Standard
Campaign Management. Administrators create and configure campaigns. They can specify a daily time range during which outbound calls are made and a set of CSQs whose agents make the outbound calls. They can also specify and import a list of customer contacts to be called.	Included.	Not available.	Not available.
Area Codes Management. Administrators can add mappings from area code to time zone for non-North American locations. This information is used to determine the customer contact current time before placing an outbound call.	Included.	Not available.	Not available.
Agent Outbound Controls. Agents can accept, reject, or skip outbound call requests. Agents can also reclassify calls to any one of many call results, such as Busy, Fax, and Answering Machine.	Included.	Not available.	Not available.
Removing “Do Not Call” Contacts. After an agent reclassifies a contact as “Do Not Call”, the Administrator can remove this contact from all campaigns.	Included.	Not available.	Not available.

Cisco Unified Email Interaction Manager

Cisco Unified Email Interaction Manager (Cisco Unified EIM) provides inbound e-mail routing, automated or agent assisted e-mail response, real-time and historical reporting and role based hierarchical rights management for agents, supervisors, administrators and knowledge base administrators. Cisco Unified EIM shares a common routing engine, services creation editor, look and feel, roles, and desktops with Cisco Unified Web Interaction Manager (Cisco Unified WIM) and is available in either a Basic or Advanced package.

Cisco Unified EIM may be deployed on a dedicated server or server cluster or share a server or server cluster with Cisco Unified WIM. When Cisco Unified EIM and WIM are deployed on shared servers or server clusters, both must be either the Basic or Advanced package. Mixing packages is not supported.

Each user license is for a concurrent user. For example, a contact center with three shifts of 100 agents and supervisors would need 100 concurrent user licenses. Each shift of 100 users would reuse these licenses during their shifts.

[Table 1-13](#) lists the Cisco Unified EIM licensed components.

Table 1-13 Cisco Unified EIM Licensed Component

License	Premium	Enhanced	Standard
Basic EIM Concurrent User.	Available.	Not available.	Not available.
Advanced EIM Concurrent User.	Available.	Not available.	Not available.

Cisco Unified EIM is packaged on a per-user basis and provides all the server software required for users, with the exception of the Windows operation system (Windows 2003) and database software (Microsoft SQL 2000), which must be purchased off the shelf.

Table 1-14 describes the Cisco Unified EIM features that are available in each Cisco Unified CCX Package.

Table 1-14 Cisco Unified EIM Features Available in Each Cisco Unified CCX Package

Feature	Premium Advanced Cisco Unified EIM	Premium Basic Cisco Unified EIM	Enhanced	Standard
Full HTML email support (incoming and outgoing).	Available.	Available.	Not available.	Not available.
Extensive knowledge base functionality—edit, search, link.	Available.	Available.	Not available.	Not available.
Flexible Attachment Handling—large attachments, from knowledge base or desktop.	Available.	Available.	Not available.	Not available.
Data adapters to integrate with external databases, HTTP, Java, Web Services, SOAP.	Available.	Database adaptor only.	Not available.	Not available.
Workflow extensibility, outbound workflows—workflows can be customized to invoke external programs, allow for approval of outbound e-mail.	Available.	Not available.	Not available.	Not available.
Custom roles.	Available.	Not available.	Not available.	Not available.
Multiple Partitions and departments.	Available.	Not available.	Not available.	Not available.

Cisco Unified Web Interaction Manager

Cisco Unified Web Interaction Manager (Cisco Unified WIM) provides inbound chat routing, agent assisted chat sessions, real time and historical reporting and role based hierarchical rights management for agents, supervisors, administrators, and knowledge base administrators. Cisco Unified WIM shares a common routing engine, services creation editor, look and feel, roles, and desktops with Cisco Unified EIM and is available in either a Basic or Advanced package.

Cisco Unified WIM may be deployed on a dedicated server or server cluster or share a server or server cluster with Cisco Unified EIM. When Cisco Unified EIM and WIM are deployed on shared servers or server clusters both must be either the Basic or Advanced package. Mixing packages is not supported.

Each user license is for a concurrent user. For example, a contact center with three shifts of 100 agents and supervisors would need 100 concurrent user licenses. Each shift of 100 users would reuse these licenses during their shift.

Table 1-15 lists the Cisco Unified WIM licensed components.

Table 1-15 Cisco Unified WIM Licensed Components

License	Premium	Enhanced	Standard
Basic WIM Concurrent User.	Available.	Not available.	Not available.
Advanced WIM Concurrent User.	Available.	Not available.	Not available.

Cisco Unified WIM is packaged on a per-user basis and provides all the server software required for users, with the exception of the Windows operation system (Windows 2003) and database software (Microsoft SQL 2000), which must be purchased off the shelf.

Table 1-16 describes the Cisco Unified WIM features that are available in each Cisco Unified CCX Package.

Table 1-16 Cisco Unified WIM Features Available in Each Cisco Unified CCX Package

Feature	Premium Advanced Cisco Unified WIM	Premium Basic Cisco Unified WIM	Enhanced	Standard
Support for callers on most browsers.	Available.	Available.	Not available.	Not available.
Integrated, searchable Knowledge bas.	Available.	Available.	Not available.	Not available.
Single desktop for chat, collaboration, email.	Available.	Available.	Not available.	Not available.
Templates to control customer experience. Defined entry points to ease deployment.	Available.	Database adaptor only.	Not available.	Not available.
Data adapters to integrate with databases, HTTP, Java, Web Services, SOAP.	Available.	Database adaptor only.	Not available.	Not available.
Configurable roles.	Available.	Not available.	Not available.	Not available.
Multiple Departments—separate administration (data not separated).	Available.	Not available.	Not available.	Not available.

Quality Management

Quality Management (QM) supports the recording and archiving of every call between agents and customers. Managers and supervisors can evaluate a customer contact by listening to the recording and filling out an electronic evaluation form. They can also monitor and analyze the performance of groups, teams, and individual agents by looking at summary and detail reports of those evaluations. Supervisors and managers can then use these results to suggest training classes for the agents to take.

Each user license is for a configured (not concurrent) user. For example, a contact center with three shifts of 100 agents and supervisors would need 300 configured user licenses. Each shift of 100 users would use the license associated with them during their shift.

Advanced QM is similar to QM except that it supports screen recording. Screen recording allows a supervisor to see what the agent was doing on the desktop at the time the agent handled a call.

Table 1-17 lists the Quality Management licensed component.

Table 1-17 Quality Management Licensed Component

License	Premium	Enhanced	Standard
Quality Management Configured User.	Available.	Not available.	Not available.
Advanced QM	Available.	Not available.	Not available.



Note

Advanced QM is available starting with Cisco Unified CCX 5.0(2).

Quality Management is packaged on a per-user basis and provides all the server software required for users, with the exception of the Windows operation system (Windows 2003) and database software (Microsoft SQL 2005), which must be purchased off the shelf.

Table 1-18 describes the Quality Management features that are available in each Cisco Unified CCX Package.

Table 1-18 Quality Management Features Available in Each Cisco Unified CCX Package

Feature	Premium QM	Enhanced	Standard	Premium Advanced QM
Endpoint recording, background software services.	Available.	Not available.	Not available.	Available.
Server-based recording (via SPAN port) for thin client environments.	Available.	Not available.	Not available.	Available.
Secure login, user role based model for access scope.	Available.	Not available.	Not available.	Available.
Agent, supervisor, manager, role based dashboards.	Available.	Not available.	Not available.	Available.
Users synchronized with CCX or administered directly in QM.	Available.	Not available.	Not available.	Available.
Evaluator/agent comment threads.	Available.	Not available.	Not available.	Available.

Table 1-18 Quality Management Features Available in Each Cisco Unified CCX Package

Feature	Premium QM	Enhanced	Standard	Premium Advanced QM
Compressed, encrypted recordings transfer during off-peak hours..	Available.	Not available.	Not available.	Available.
Append custom metadata to recordings for enhanced search.	Available.	Not available.	Not available.	Available.
On-demand call tagging.	Available.	Not available.	Not available.	Available.
Partial call recording.	Available.	Not available.	Not available.	Available.
Monitoring and notification service (serviceability).	Available.	Not available.	Not available.	Available.
Quality evaluation approval process.	Available.	Not available.	Not available.	Available.
Screen recording	Not available.	Not available.	Not available.	Available.

Workforce Management

Cisco Workforce Management allows supervisors and contact center managers to develop schedules for their agents and manage key performance indicators and real-time adherence. Managers can create and manage schedules for an unlimited number of sites, manage scheduling for offices spread out in different time zones, and schedule alternative media sources seamlessly, including chat and e-mail.

Each user license is for a configured (not concurrent) user. For example, a contact center with three shifts of 100 agents and supervisors would need 300 configured user licenses. Each shift of 100 users would use the license associated with them during their shift.

[Table 1-19](#) lists the Workforce Management licensed component.

Table 1-19 Workforce Management Licensed Component

License	Premium	Enhanced	Standard
Workforce Management Configured User.	Available.	Not available.	Not available.

[Table 1-20](#) describes the Workforce Management features that are available in each Cisco Unified CCX Package.

Table 1-20 Workforce Management Features Available in Each Cisco Unified CCX Package

Feature	Premium	Enhanced	Standard
Forecasting	Available.	Not available.	Not available.
2-step scheduling	Available.	Not available.	Not available.
Multimedia Scheduling	Available.	Not available.	Not available.

Table 1-20 Workforce Management Features Available in Each Cisco Unified CCX Package

Feature	Premium	Enhanced	Standard
Intraday management	Available.	Not available.	Not available.
KPIs and reporting	Available.	Not available.	Not available.
Alerts	Available.	Not available.	Not available.
Reporting	Available.	Not available.	Not available.
Web interface	Available.	Not available.	Not available.
Desktop integration	Available.	Not available.	Not available.



CHAPTER 2

Cisco Unified Contact Center Express Solution Architecture for Cisco Unified Communications Manager

Cisco Unified CCX, Release 7.0, is a solution composed of many components. These components include not just the Cisco Unified CCX software and the servers upon which that software runs, but also include Cisco Unified Communications Manager (Cisco Unified CM), Cisco routers, Cisco data switches, Cisco Voice Gateways, and Cisco IP Phones. Cisco Unified CCX software is part of the Cisco Unified Contact Center Express (Cisco Unified CCX) software platform. Cisco Unified CCX provides the software capabilities for not just Cisco Unified CCX, but also Cisco Unified IP IVR. (Note that Extended Services is no longer offered as part of Cisco Unified CM for either Cisco CRS 3.5 or 4.0 releases.) Cisco Unified IP IVR is primarily used for Cisco Unified Contact Center Enterprise (Cisco Unified CCE) deployments. A single physical server can run only one of the Cisco Unified CCX packages, either Cisco Unified CCX or Cisco Unified IP IVR.

This chapter includes the following sections:

- [Cisco Unified CCX Terminology, page 2-2](#)
- [Cisco Unified CCX Call Processing, page 2-4](#)
- [Cisco Unified CCX System Management, page 2-5](#)
- [Cisco Unified CCX Engine and Database Components, page 2-6](#)
- [Monitoring and Recording Components, page 2-6](#)
- [Cisco Unified Wireless IP Phone 7920 IP Phone Support, page 2-9](#)
- [SIP Support, page 2-10](#)
- [Citrix Terminal Services Support for Cisco Agent Desktop, page 2-10](#)
- [Remote Agent Over Broadband, page 2-11](#)
- [Cisco TelePresence Virtual Agent Solution, page 2-11](#)
- [Cisco Unified CCX Outbound Preview Dialer, page 2-13](#)
- [Cisco Interaction Manager, page 2-16](#)
- [Cisco Unified CCX Agent E-Mail, page 2-17](#)
- [Cisco Agent Desktop Integration with Cisco Unified Presence, page 2-20](#)
- [Agent Phones in Countries with Toll-Bypass Regulations, page 2-22](#)
- [Cisco Unified Workforce Optimization, page 2-22](#)
- [Cisco Unified CCX ASR and TTS, page 2-23](#)

- [Cisco Unified CCX Integration with Unified ICME Software, page 2-24](#)
- [Cisco Unified CCX Fault Tolerance, page 2-27](#)
- [Cisco Unified CCX 7.0 Software Compatibility, page 2-31](#)

Cisco Unified CCX Terminology

The Cisco Unified CM Telephony subsystem provides a mechanism for Cisco Unified CCX to communicate with Cisco Unified CM for call processing. Within Cisco Unified CM, an application user with CTI permissions is defined and that user ID is used by the Cisco Unified CM Telephony subsystem to log into Cisco Unified CM through JTAPI messaging. This user ID is referred to as the Cisco Unified CM Telephony user ID. This login process is what allows Cisco Unified CCX to begin communications with Cisco Unified CM and offer services like routing control.

When a caller dials the number of an extension configured on an IP Phone, Cisco Unified CM is capable of setting up that call without the aid of Cisco Unified CCX. However, sometimes callers dial generic numbers that are not associated with any particular phone. In those situations, Cisco Unified CM needs a mechanism to request routing instruction from some other application. One such mechanism is a route request message and one such application that can provide routing control is Cisco Unified CCX. In order for Cisco Unified CM to request routing from another application for a particular dialed number, there must be a CTI Route Point defined within Cisco Unified CM for that dialed number. In Cisco Unified CCX, this CTI Route Point is defined in the Cisco Unified CM Telephony Trigger. Within Cisco Unified CM the CTI Route Point is also associated with the user (application) that can provide routing control. This Cisco Unified CM configuration is what enables Cisco Unified CM to ask Cisco Unified CCX how to route a call. The creation of a CTI Route Point, the association of that CTI Route Point to the dialed number, and the user association of that CTI Route Point to the Cisco Unified CM Telephony user responsible for routing control is done automatically by the Cisco Unified CCX Server as part of the creation of a Cisco Unified CM Telephony trigger within Cisco Unified CCX.

The Cisco Unified CM Telephony trigger also specifies what CTI port group and Cisco Unified CCX application to use for a specified dialed number. As discussed in Chapter 1, Cisco Unified CCX provides IVR functionality. A Cisco Unified CCX system can provide up to 300 logical IVR ports (also called CTI Ports). The CTI ports within Cisco Unified CCX are logical VoIP endpoints where calls can be terminated—very similar to a softphone. The difference is that these softphones are controlled by an application that has the ability to encode .wav files from disk into one of the supported VoIP formats (G.711 or G.729) and then stream those VoIP packets out the Ethernet interface on the Cisco Unified CCX Server to the calling VoIP endpoint (IP Phone or Voice Gateway port). Each CTI Port must be defined within Cisco Unified CM as a device with a type of “CTI Port.” Each CTI Port device is assigned a unique directory number (extension), just like a phone. This allows Cisco Unified CM to setup calls to these devices and endpoints. The creation of the CTI Ports on Cisco Unified CM is done automatically by the Cisco Unified CCX server when a group of CTI Ports (Call Control Group) is defined.

When a caller dials a dialed number that is associated with a CTI Route Point, Cisco Unified CM sends a route request to Cisco Unified CCX which has the dialed number associated with a group of CTI Ports. The Cisco Unified CCX software selects an available CTI Port from that CTI Port Group and returns the extension of that CTI Port to Cisco Unified CM. Cisco Unified CM then attempts to setup a call to that extension (CTI Port) by sending a ring message to the Cisco Unified CCX server. When the Cisco Unified CCX server gets the ring message for a particular CTI Port for a particular dialed number, the Cisco Unified CCX server begins executing the script associated with that trigger’s application. The first step in a script is typically an Accept step. The Accept step in the application will answer the call by sending a message to Cisco Unified CM to establish an RTP stream between the selected CTI Port and

the Voice Gateway (VG) port (or calling IP Phone). The application can then prompt callers for input and provide the caller self service. When either the caller hangs up or the application executes a Terminate step, Cisco Unified CM tears down the call.

Within the application, it is also possible to route or transfer the call to an available agent. If no agents are available, queueing treatment is provided to the caller. Agents in Cisco Unified CCX are called resources. There is a subsystem within Cisco Unified CCX called the Resource Manager which is responsible for monitoring the state of agents and selecting agents based upon the agent skills and queue skills required. Queues in Cisco Unified CCX are called Contact Service Queues (CSQs). Agents use Cisco Agent Desktop (CAD) or IP Phone Agent (IPPA) state controls to log in and make themselves ready. The Resource Manager is updated upon every agent state change.

Administrators use the Cisco Unified CCX Administration web interface to configure agent skills and competencies. Cisco Unified CCX Administration is also used to define CSQ skill and competency requirements and the agent selection criteria to be used for that CSQ. Applications use the Select Resource step to specify the CSQ into which the caller shall be placed. The Resource Manager subsystem is queried by the application to select the appropriate agent based upon the agent selection criteria. If no agent is available, the Select Resource step has a queued branch where queueing treatment is defined. When the Resource Manager finds an available and appropriately skilled agent, it will reserve that agent and then request for that call to be transferred to the agent's IP Phone (using JTAPI messaging to Cisco Unified CM). After the call has been transferred to and answered by the agent, the CTI Port being used for that call is released.

An agent must be configured in Cisco Unified CM as a user. This adds a record to the Cisco Unified CM user table. The Cisco Unified CM user table can be synchronized with LDAP directories like Microsoft's Active Directory. Details on LDAP integration can be found in Appendix C. Cisco Unified CM supports usage of one of the following LDAP directory servers—DC Directory (default), Netscape IPlanet, and Microsoft Active Directory. In Cisco Unified CM, an agent's phone and directory number are associated with the agent's Cisco Unified CM user name and the directory number is also marked as a Cisco Unified CCX extension. This allows Cisco Unified CCX to know that this Cisco Unified CM user is an agent, and the user then shows up in the resource list in Cisco Unified CCX Administration.

In Cisco Unified CM, agent phones also are associated with another application user with CTI permissions called the Resource Manager user. This user is referred to as the RmCm Provider. The RmCm Provider allows Cisco Unified CCX to monitor the state of the phone. For example, when an agent goes off hook to make an outbound call using the Cisco Unified CCX extension, the Cisco Unified CCX application needs to be notified so that the Resource Manager can update its agent state machine to show that agent being on an outbound call. The RmCm Provider also allows Cisco Unified CCX to control the state of the phone. For example, when an agent clicks Answer on CAD, this triggers Cisco Unified CCX to have the RmCm Provider signal to Cisco Unified CM to have that agent's phone go off hook.

Cisco Unified CCX Call Processing

Figure 2-1 and the description that follows explain a typical Cisco Unified CCX call flow:

Figure 2-1 Cisco Unified CCX Call Flow

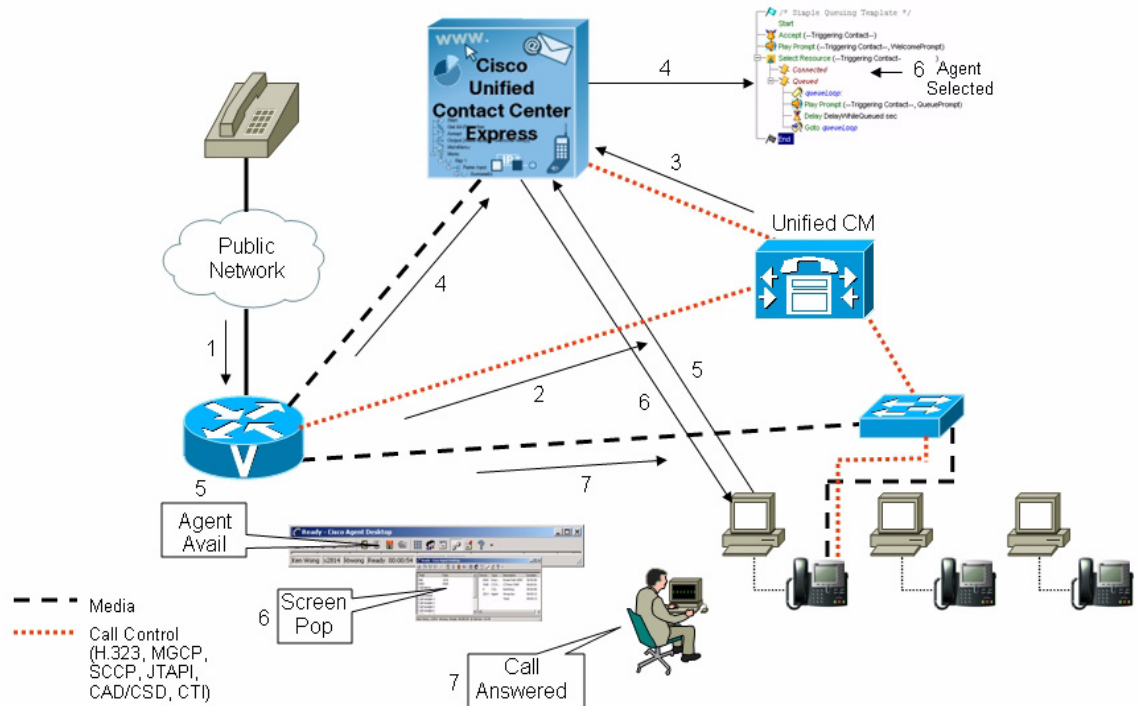

1. Call arrives at Voice Gateway (VG)
2. Voice Gateway asks Unified CM how to route the call (using H.323 or MGCP).
3. Cisco Unified CM has the dialed number (DN) associated with a CTI Route Point that is associated with a Cisco Unified CM Telephony user for Cisco Unified CCX. This triggers a JTAPI route request to be sent to Cisco Unified CCX.
4. Based upon the DN, which is mapped to a Cisco Unified CM Telephony trigger, the Cisco Unified CCX server selects an available CTI port and replies back to Cisco Unified CM with the extension of the CTI Port to send this call to. Cisco Unified CM then sends a call setup (ring) message to Cisco Unified CCX, which then maps the DN to the appropriate Cisco Unified CCX script. The Accept step (typically the first step) in the script will answer the call and trigger Cisco Unified CM to establish an RTP stream between the Voice Gateway port and the selected CTI Port. Then the script prompts the caller for an account number and does a database lookup. Then the caller is prompted to select from a menu of choices and is provided self-service treatment. If the user presses 0, we go to the transfer to agent section of the script. In this scenario, we are assuming no appropriately skilled agents are available, so the script executes the queued loop logic until an appropriately skilled agent becomes available.
5. An appropriately skilled agent becomes available as a result of logging in and going ready or completing a previous call.

6. The agent is selected or reserved by the Cisco Unified CCX server and this triggers the call to be transferred to the agent phone and subsequently causes the agent phone to ring (using Cisco Unified CM signaling). In addition, the Cisco Unified CCX server delivers a screen pop to the selected agent desktop and enables the answer button on the agent desktop.
7. The agent answers the call which causes Cisco Unified CCX to complete the transfer from the CTI Port to the agent phone and Cisco Unified CM to initiate the establishment of an RTP VoIP data stream between the agent's phone and the VG port. The transfer releases the CTI Port on the Cisco Unified CCX server. But the Cisco Unified CCX software continues to monitor the agent state for the duration of that call. When the agent or caller releases, a Contact Call Detail Record (CCDR) is written to the CCDR table in the database, and the agent's state is updated to reflect the agent's new state (work, ready, or not ready).

Cisco Unified CCX System Management

Several applications are available for administering and monitoring a Cisco Unified CCX deployment. The primary tool an administrator uses to manage a Cisco Unified CCX deployment is the Cisco Unified CCX Administration web interface. Cisco Unified CCX Administration is a web-based application accessed using a Windows Internet Explorer 6.0 or above browser. Using Cisco Unified CCX Administration, administrators perform tasks such as uploading applications, uploading prompts, mapping applications to dialed numbers, configuring agent skills and CSQs, starting and stopping Cisco Unified CCX subsystems, and monitoring overall server status.

In addition to Cisco Unified CCX Administration, an administrator uses the Cisco Unified CCX Editor. The Cisco Unified CCX Editor is a client-based utility that produces .aef files which the administrator uploads using Cisco Unified CCX Administration. The Cisco Unified CCX Editor is automatically installed on the Cisco Unified CCX server by default. The Cisco Unified CCX Editor can also be downloaded and installed from Cisco Unified CCX Administration onto other workstations.

The Cisco Desktop Administrator (CDA) is another client-based utility that can be downloaded and installed from Cisco Unified CCX Administration. It is installed on the Unified CCX server by default. CDA allows an administrator to perform tasks such as configuring the agent interface, setting up reason codes, and defining agent workflows and keystroke macros.

Another client utility to monitor a Cisco Unified CCX deployment is the Historical Reports client application. You download and install the Historical Reports client from Cisco Unified CCX Administration. There are 34 historical reporting templates available. Taken in combination with filtering parameters and chart or no chart options, there are 282 possible reports available. Some of them provide integrated information about voice and multichannel activities. Custom reporting templates can be created with Crystal Reports development toolkit. Within Cisco Unified CCX Administration, there are also 11 browser-based real-time reports. The CSD and CAD both also provide reports to allow real-time monitoring of a Cisco Unified CCX deployment. Both CSD and CAD are downloaded and installed from Cisco Unified CCX Administration.

For additional information about Cisco Unified CCX Administration, see the *Cisco Unified CCX Administration Guide*.

Cisco Unified CCX Engine and Database Components

Cisco Unified CCX has four core software components:

- Cisco Unified CCX Engine
- Database
- Monitoring
- Recording

Every Cisco Unified CCX deployment must have a Cisco Unified CCX Engine component and a Database component. The Monitoring and Recording components are optional and are discussed in the next section of this chapter. With Cisco Unified CCX 7.0, only one instance of each of these components can be installed, and all components must be on the same server.

The Cisco Unified CCX Engine (and closely related subsystems) is the component that provides functions like the following:

- JTAPI communications with Cisco Unified CM
- Execution of scripts
- Encoding and streaming of .wav files for all CTI Ports defined
- Communications with CAD for agent state control, call control, and screen pop
- Agent monitoring and selection
- Cisco Unified CCX Administration web interface.

Simply put, one can think of the Cisco Unified CCX Engine component as providing the core ACD, IVR, and CTI services. The other components—Database, Monitoring, and Recording—are auxiliary software components.

The Database component is a required component for any Cisco Unified CCX deployment and is the component that manages access to the database. The Cisco Unified CCX Database contains four data stores. They are as follows:

- Configuration data store
- Repository data store
- Agent data store
- Historical data store

The configuration data store contains Cisco Unified CCX configuration information like Resources (agents), skills, resource groups, teams, and CSQ information. The repository data store contains user prompts, grammars, and documents. The agent datastore contains agent logs, statistics, and pointers to the recording files. The historical data store contains Contact Call Detail Records (CCDRs).

Monitoring and Recording Components

The previous section introduced the Cisco Unified CCX Engine and Database components. This section introduces the Monitoring and the Recording components, which are optional.

Cisco Unified CCX Enhanced and Premium provide the ability for a supervisor to silently monitor agents. Cisco Unified CCX Enhanced and Premium also provide the ability for agent calls to be recorded. Agent call recording can be triggered in the following ways:

- Supervisor clicks record button on CSD for a specified agent call

- Agent clicks record button on CAD or IPPA.
- Workflow configuration automatically triggers complete call recording on certain types of calls for agents using CAD.

In order to use the silent monitoring or recording features, access to the RTP (Real-Time Protocol) packet streams is required. Silent monitoring and recording will work with either G.711 or G.729 RTP streams and a mixture of agents using G.711 and G.729 phones is supported. However, silent monitoring and recording will not work with encrypted media streams. Cisco Unified CCX provides two mechanisms for access to the RTP packet stream—SPAN port monitoring and desktop monitoring.

SPAN port monitoring requires the Cisco Unified CCX server to be connected to the SPAN port of a VLAN on a Catalyst switch where the agent phones are installed. The SPAN port is like a broadcast port for all data traffic (including voice RTP streams) traversing a VLAN segment. When a supervisor clicks the silent monitor button on the CSD, it signals to the Monitoring component to forward a copy of the captured RTP streams for the selected agent to the requesting CSD. The CSD then plays the packets through the sound card on the CSD workstation. No IP Phone (or any type of phone) is involved when the silent monitoring stream is being played using CSD. The CSD can reside anywhere on the Cisco Unified Communications network, but the agent's phone must be on the same VLAN where the Cisco Unified CCX server is installed. The Catalyst switch RSPAN feature allows a VLAN to extend across multiple Catalyst switches. Please refer Appendix B for more detail on SPAN port monitoring design guidance.

**Note**

For any deployment in which an agent desktop is the IPPA or any deployment in which the desktop is a CAD and the associated phone does not support desktop (endpoint) monitoring, monitoring and recording have to be based on SPAN port monitoring. For a list of phones that support desktop (endpoint) monitoring, refer the *Cisco Unified CCX Software and Hardware Compatibility Guide*, which is available at:

http://www.cisco.com/en/US/products/sw/custcosw/ps1846/products_device_support_tables_list.html

Desktop monitoring provides a mechanism for the CAD application to obtain a copy of the RTP packet streams directly from the phone and therefore removes the need for a Monitoring component connected to the SPAN port on the Catalyst switch. A Cisco phone supporting desktop monitoring is required and the agent workstation running CAD must be connected to the data port on the back of the agent phone. The IP Communicator (softphone) also supports using desktop monitoring for silent monitoring and recording.

**Note**

For all deployments in which agents use CAD and agent phones support desktop monitoring, use desktop monitoring instead of SPAN port monitoring.

When a supervisor clicks the silent monitor button on the CSD for an agent using desktop monitoring, the RTP streams are sent directly from CAD to CSD, and the SPAN port monitoring component is not required. However, for silent monitoring to occur with desktop monitoring, there must be at least one VoIP Monitor service running. This service is used by CAD to retrieve the MAC address of the agent phone from the Cisco Unified CM. For desktop monitoring, the agent workstation must have a NIC that supports 802.1Q. This allows the NIC to process packets from both the data and voice VLANs. Appendix C of the *Cisco CAD Installation Guide* provides a quick and simple test to determine if a workstation NIC will operate properly with the desktop monitoring feature of CAD.

A Cisco Unified CCX deployment can have a mixture of some agents using desktop monitoring and some agents using SPAN port monitoring.

If an agent call requires recording, then a copy of the RTP packet streams is sent to the Recording Server process. If desktop monitoring is being used by the agent being recorded, then CAD sends the RTP streams to the Recording component. If SPAN port monitoring is being used by the agent being recorded, then the Monitoring component sends the RTP streams to the Recording component. Agents can be silently monitored and recorded at the same time. When that occurs in a desktop monitoring environment, CAD sends one copy of the RTP packet streams to the requesting CSD and one copy of the RTP packet streams to the recording component.

A normal G.7xx VoIP RTP call has two RTP streams (one representing what the agent is hearing and one representing what the agent is saying). These two streams flow in opposite directions across the network. When an agent call is being silently monitored or recorded, both of those RTP streams must be sent. For example, if a supervisor is silently monitoring an agent, two G.7xx RTP streams will be sent from either CAD (desktop monitoring) or the Monitoring component to the CSD. If an agent call is being recorded, two G.7xx RTP streams are sent to the Recording component. If the agent is being silently monitored and recorded, four RTP streams are being sent. This is in addition to the two bi-directional RTP streams of the actual call.

The monitoring and recording packet streams are true G.7xx RTP streams and therefore these packets are tagged like any other RTP stream to ensure these packets are delivered with appropriate priority and minimal latency. Chapter 6 further discusses bandwidth requirements.

The agent call recordings are stored on the hard drive of the Cisco Unified CCX server with agent data store locator records pointing to the actual recording files. The call recordings in Cisco Unified CCX 7.0 are stored in a raw format that is only playable using the CSD Record Viewer. The CSD Record Viewer shows 7 days worth of call recording as well as those tagged for 30-day extended archiving. The CSD Record Viewer also provides the supervisor the option to save selected individual recordings into a .wav format in a specified folder.

The recording capability of Cisco Unified CCX is not intended for usage as a permanent recording archival solution. However, an export utility is also available to bulk export all recordings into a .wav format. The export utility has no ability to specify selected recordings and will export all recordings on the Cisco Unified CCX server. System administrators could build their own customized command macros or process that would perform regular (at least weekly) exporting of the recordings for permanent archival of agent call recordings.

With Cisco Unified CCX Enhanced and Premium, up to 32 simultaneous agent calls can be recorded. When a supervisor is playing back or saving a recording using the CSD Record Viewer application, a recording resource is used and therefore counts against the maximum simultaneous call recording capacity for the duration of that recording playback. Maximum simultaneous call recording and playback capacity is dependent upon the server sizing. The Configuration and Ordering tool can assist you in determining an appropriately sized server for the amount of recording required.

Because IPPA does not include an agent using CAD, IPPA requires a SPAN port Monitor component on the local VLAN segment for silent monitoring or recording. Also the Cisco Unified IP Phone 7902, 7905, 7912, and 7920 require a SPAN port Monitor component as there are either no data ports on these phones or these data ports are not compatible with desktop monitoring. IPPA also cannot be configured to have calls automatically recorded.

Cisco Unified CCX Premium is required for remote supervisory monitoring. Remote supervisory monitoring provides a mechanism to silently monitor calls using an IP Phone or PSTN phone. This form of silent monitoring does not require a CSD or any data network connectivity and is ideally suited for management from outsourcer customers of a call center service provider. Agents are unaware when they are being silently monitored using remote supervisory monitoring. A remote supervisor is configured with a numeric user ID and password and also with the CSQs and agents that the remote supervisor is allowed to silently monitor in this fashion. The remote supervisor then dials a specific number that invokes a Cisco Unified CCX application. The application begins by prompting the supervisor for the user ID and password. After the remote supervisor is authenticated, the remote supervisor is prompted on whether

they wish to silent monitor calls for a specific agent or for a specific CSQ. Then the Cisco Unified CCX application requests a copy of the RTP streams for the selected types of calls, and the Cisco Unified CCX application and CTI Port relays those packets to the remote supervisor's phone. Remote supervisory monitoring works with both SPAN port monitoring and desktop monitoring. However, remote supervisory monitoring only works with a Cisco Unified CCX Engine and CTI Ports and agent phones using G.711 encoding. Remote supervisory monitoring also places an additional performance impact on the Cisco Unified CCX server Cisco Unified CCX Engine. This activity is reflected in the Cisco Unified CCX 7.0 Configuration and Ordering Tool.

Cisco Unified Wireless IP Phone 7920 IP Phone Support

Cisco Unified CCX supports use of the Cisco Unified Wireless IP Phone 7920 Wireless IP Phone by agents. Agents can be using CAD with the Cisco Unified Wireless IP Phone 7920 Wireless IP Phone, or agents can use the IPPA interface with the Cisco Unified Wireless IP Phone 7920 Wireless IP Phone. When planning to use the Cisco Unified Wireless IP Phone 7920 for agents with Cisco Unified CCX, the following considerations need to be taken into account:

- If a logged in agent using a Cisco Unified Wireless IP Phone 7920 Wireless IP Phone roams outside Wireless Access Point (WAP) range for greater than 60 seconds (possibly slightly longer depending upon Cisco Unified CM time out), Cisco Unified CM unregisters the Cisco Unified Wireless IP Phone 7920 Wireless IP Phone (and ends any call in progress if the Cisco Unified Wireless IP Phone 7920 Wireless IP Phone was off hook). This generates a device unregistered JTAPI event to be sent to Cisco Unified CCX which causes the Cisco Unified CCX agent state to change to 'not ready'. When agents roam between WAPs, the hand off occurs within a second or two (depending upon wireless LAN design, encryption, and authentication techniques used). Therefore, roaming between WAPs is supported. If an agent is using the Cisco Unified Wireless IP Phone 7920 Wireless IP Phone with CAD, but is away from the CAD workstation, there is no way for the agent to know that the agent state is 'not ready' and there is no way for the agent to change the agent state to 'ready'. If the agent is using the Cisco Unified Wireless IP Phone 7920 Wireless IP Phone with IPPA, then the agent can check the agent state via IPPA and can change the agent state to 'ready' via IPPA. Therefore, if agents anticipate roaming outside WAP range for greater than 60 seconds, then it is recommended that they log in to Cisco Unified CCX via IPPA for that login session. If agents anticipate working at their desk or not roaming outside WAP range, then it is okay for them to log in to Cisco Unified CCX via CAD for that login session.
- The Cisco Unified Wireless IP Phone 7920 Wireless IP Phone is not supported as a second-line appearance for a wired IP phone for the Cisco Unified CCX agents. Second-line appearance is not supported for IPPA.
- Cisco WAPs currently support only a maximum of seven G.711 or eight G.729 active calls. Therefore, do not have a large volume of agents in one location all using the Cisco Unified Wireless IP Phone 7920 Wireless IP Phone. The maximum number of agents that can be equipped with Cisco Unified Wireless IP Phone 7920 Wireless IP Phones depends upon the agent utilization of the phone during busy hour, the codec being used by the phone, and the proximity of agent phones to WAPs.
- Use of the Cisco Unified Wireless IP Phone 7920 Wireless IP Phone as an agent phone requires using SPAN port monitoring for supervisory silent monitoring and call recording. This applies to the Cisco Unified Wireless IP Phone 7920 Wireless IP Phone when used with either CAD or IPPA. The port that is to be included in the SPAN is the one to which the WAP is wired. Cisco Unified CCX 7.0 supports only one monitoring domain. However, that monitoring domain may include multiple WAPs on the same VLAN segment. This will allow agents to roam between WAPs and still be silently monitored by supervisors and have their calls recorded. For Cisco Unified Wireless IP Phone 7920 Wireless IP Phone caller to Cisco Unified Wireless IP Phone 7920 Wireless IPPA phone

conversations where both are on the same WAP, the RTP stream will not leave the WAP and thus will never traverse the LAN segment that the SPAN port monitoring server is monitoring. Therefore, silent monitoring or recording of those phone calls is not possible.

- For more details on designing wireless LANs with optimal Cisco Unified Wireless IP Phone 7920 Wireless IP Phone QoS and necessary security, please reference the campus design Solution Reference Network Design (SRND) documents for wireless LAN and Cisco Unified Wireless IP Phone 7920 Wireless IP Phone. These SRNDs can be found at:

<http://www.cisco.com/go/designzone>

SIP Support

Cisco Unified CCX agents may use Cisco Unified CM Session Initiation Protocol (SIP) phone models 7941, 7961, 7970, and 7971. The 7940 and 7960 phones do support SIP with Cisco Unified CM 5.x and 6.x but may not be used for Cisco Unified CCX agents, because the necessary third-party call control and monitoring required is not present. The lower-end phone models are also not available to be used as SIP phones for Cisco Unified CCX agents. SCCP support for Cisco IP Phones continues to be supported for agent phones.

Cisco Unified CCX CTI ports are notified of caller-entered digits (DTMF input) via JTAPI messages from Cisco Unified CM. Cisco Unified CCX does not support any mechanism to detect in-band DTMF digits where DTMF digits are sent with voice packets. In deployments with voice gateways or SIP phones that only support in-band DTMF or are configured to use in-band DTMF, an MTP resource must be invoked by Cisco Unified CM to convert the in-band DTMF signalling so that Cisco Unified CM can notify Cisco Unified CCX of the caller-entered digits. Be sure to enable out-of-band DTMF signalling when configuring voice gateways in order to avoid using the previous MTP resources. For detailed design consideration related to DTMF handling, media resources and voice gateway deployments, please refer the *Cisco Unified Communications Solution Reference Network Design (SRND)*.

Citrix Terminal Services Support for Cisco Agent Desktop

Cisco Unified CCX supports the running of CAD within a Citrix terminal services environment. When planning to use Citrix terminal services for CAD, the following considerations need to be taken into account:

- The agent must be using a Cisco IP Phone (that is, no softphone)
- CSD and Cisco Desktop Administrator (CDA) are not supported in a Citrix terminal services environment.
- Desktop monitoring (for silent monitoring and recording) is not supported with Citrix terminal services. SPAN port monitoring must be used.
- Macros work only if they involve applications running on the Citrix server, and not those running on the client PC.
- Only one Citrix user name is supported per CAD application login.
- The login ID and extension that appear by default in the login dialog box when CAD is started are those associated with the last login by any user.
- The Citrix web client is not supported.

Please reference *Integrating CAD with Citrix Presentation Server or Microsoft Terminal Services* for implementation details. This document can be found at:

http://www.cisco.com/en/US/products/sw/custcosw/ps427/products_implementation_design_guides_list.html

Remote Agent Over Broadband

Cisco Unified CCX supports remote agents (for example, at-home agents) using Cisco Unified IP Phone over a broadband internet connection. The Cisco Voice and Video Enabled IPsec VPN (V3PN) ADSL or Cable connection can use a Cisco 800 Series router as an edge router to the broadband network. The Cisco 800 Series router can provide the remote agent with V3PN, Encryption, Network Address Translation (NAT), Firewall, Cisco IOS Intrusion Detection System (IDS), and QoS on the broadband network link to the Cisco Unified CCX campus. Remote agent V3PN aggregation on the campus is provided via LAN to LAN VPN routers.

Cisco recommends using the Cisco 800 Series router with the following features for remote agent over broadband:

- Quality of Service (QoS) with Low-Latency Queuing (LLQ) and Class-Based Weighted Fair Queuing (CBWFQ) support
- Managed Switch
- Power over Ethernet (optional)

The Cisco 830, 870, and 880 Series routers are examples of the recommended routers. Cisco does not recommend using the Cisco 850 and 860 Series routers for this application because they have limited QoS feature support.

Cisco TelePresence Virtual Agent Solution

The Cisco TelePresence Virtual Agent solution enables organizations to create a live, “face-to-face” interaction with their customers—over the network with Cisco TelePresence. The life-size, high-definition video, CD-quality audio, and interactive elements of the TelePresence solution give customers the feeling of being “in person” with a specialist agent, while the agent maintains all of the contact center functions they would expect.

For example, a national bank has a limited number of property insurance specialists on staff, resulting in customers being unable to receive the guidance and service the bank wants to deliver. By providing insurance and mortgage experts at branch offices through Cisco TelePresence Virtual Agent, quality service is always available to customers. At the bank branch, a customer can enter an office designated for the virtual agent, make a selection on the Cisco Unified IP Phone, and have a in-person remote meeting with an expert.

This solution consists these hardware and software components:

- Cisco TelePresence System with single screen, for example, CTS-1000
- Cisco Unified CM
- Cisco Unified CCX Software
- Cisco Unified IP Phone 7970G (SIP), for caller and agent
- Cisco Agent Desktop Software

Cisco Unified IP Phone 7970G phone includes the Cisco IP Phone Service, the contents of which are pushed over from the primary codec in XML format over HTTP. The phone provides the user interface to interact with the primary codec for call control and other functions. The phone and primary codec are registered with Cisco Unified CM as SIP devices and they share the same line appearance. However, on the agent side, the phone is associated with the RmCm Provider user so that Cisco Unified CCX can monitor the phone for any state changes. Because call signaling and media stream traverse through the primary codec (but not the agent phone), the following guidelines apply:

- Agent must perform all call control actions from the phone but not from CAD.
- Supervisor cannot perform barge-in or intercept from CSD.
- Calls cannot be monitored or recorded.

Cisco TelePresence supports both wideband/AAC and G.711 audio codec. However, the virtual agent solution only supports G.711, which is the common supported audio codec between Cisco Unified CCX and Cisco TelePresence. Cisco recommends using Wideband/AAC audio codec for inter- or intra-region setting when configuring Cisco TelePresence device, In this case, Cisco TelePresence will automatically negotiate down to G.711 when connecting to Cisco Unified CCX.

Figure 2-2 and the description that follows explain the virtual agent solution call flow:

Figure 2-2 Cisco TelePresence Virtual Agent Call Flow

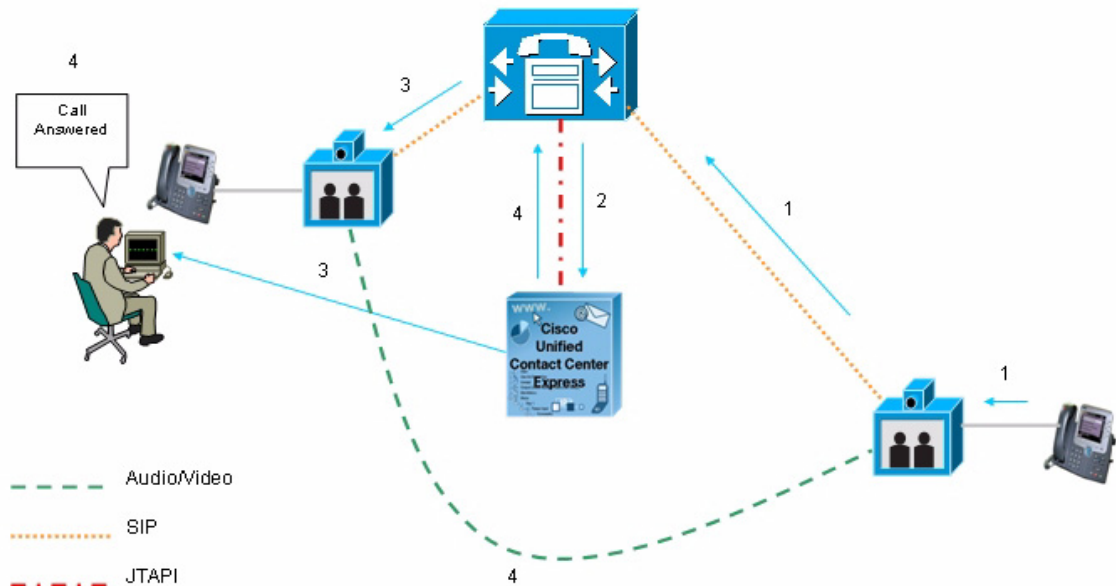

1. Customer (caller usually calls inside the corporate network) dials a number to reach an application.
2. Cisco Unified CM finds the dialed number associated with a CTI route point that is associated with a Cisco Unified CCX Unified CM Telephony user for Cisco Unified CCX. This event triggers a JTAPI route request to be sent to Cisco Unified CCX.
3. Based upon the DN, which is mapped to a Cisco Unified CM Telephony trigger, Cisco Unified CCX finds an available CTI port and redirects the call to the port. Cisco Unified CCX runs a script that finds an available agent and reserves the agent. The call is transferred to the primary codec on the agent side and the call is presented to the agent device.

4. The agent presses the answer button on the agent device to answer the call. This action causes Cisco Unified CCX to instruct Cisco Unified CM to complete the transfer and establishes audio and video between the Cisco TelePresence devices.

**Note**

For more design details, refer Cisco TelePresence Network System Design Guide available at <http://www.cisco.com/go/designzone>.

Cisco Unified CCX Outbound Preview Dialer

Cisco Unified CCX Outbound Preview Dialer (Outbound) allows Outbound agents to participate in outbound campaigns in addition to handling inbound calls. This feature selects those agents who are not busy with inbound calls to handle outbound calls, thereby maintaining a high level of agent productivity.

The following sections explain the solution architecture for Outbound in the context of Cisco Unified CM:

- [High Level Components, page 2-13](#)
- [Functional Description, page 2-14](#)
- [Scalability, page 2-15](#)
- [Call Flow Description—Direct Preview Mode](#)
- [Deployment Guidelines, page 2-16](#)

High Level Components

Outbound uses CAD agent IP phone to place outbound calls through a voice gateway configured in Cisco Unified CM. The dialer software is IP based and does not require any telephony cards for making outbound calls.

Outbound involves the following components, which are illustrated in [Figure 2-3](#):

- Campaign Manager—Responsible for starting and stopping each campaign and retrieving and updating contact records from and to the database.
- Dialer—Receives contacts from the Campaign Manager and initiates the outbound calls. Notifies the Campaign Manager of the call status and call result after the call is answered.
- Resource Manager—Monitors agent states, reserves agents and receives instructions from the Dialer to place the outbound call.
- CTI Server—Handles requests and responses from and to the CAD and passes the customer data to the CAD for screen pop.
- Config Datastore (CDS)—Database that contains the customer contacts information.

All of these components are running as part of the Cisco Unified CCX Engine and cannot be installed separately. The Dialer communicates only with the Campaign Manager and other components within the engine process but not outside of the engine process. It does not communicate with other processes.

Figure 2-3 Cisco Unified OUTDX Components

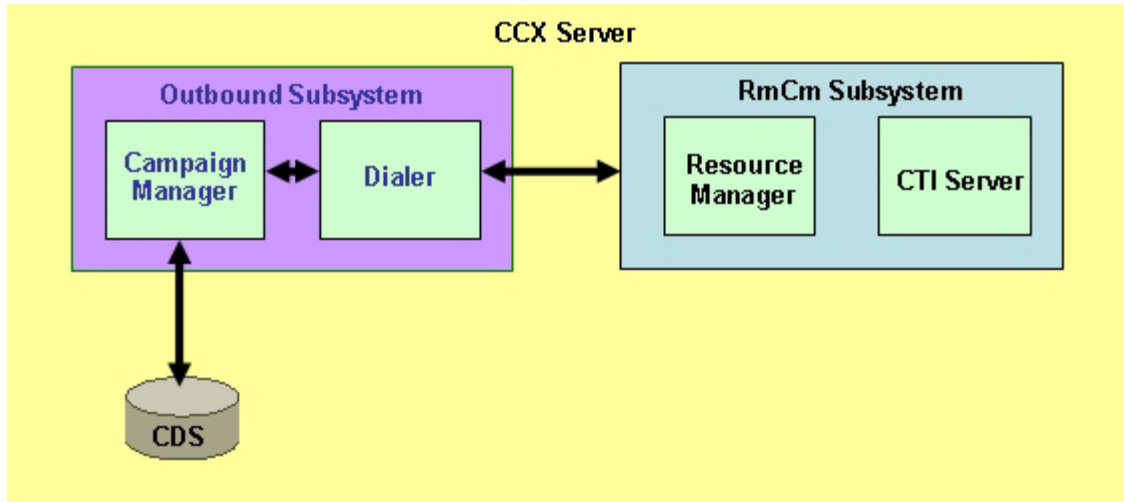

Functional Description

There are typically four types of dialing modes in today's outbound ACDs: predictive, progressive, preview, and direct preview. Outbound supports only the direct preview dialing mode.

Outbound uses a 3-stage process for making outbound call. The first stage is to find an available agent and retrieve the customer information for making the outbound call. The second stage is the reservation call and its purpose is to reserve an agent and send customer data to the agent desktop. During this stage, the agent is reserved and the data appears on the desktop so that the agent can review the data and decide whether to accept the call by pressing the corresponding button on the CAD. If the agent does not accept the call, the call is handled by other outbound agents or closed for the campaign. If the agent does accept the call, Outbound kicks in the last stage where Cisco Unified CM is instructed to place the outbound call using the CAD agent's phone. When the outbound call is answered, Outbound updates the customer contact in the database with the call status and call result.

When the outbound call connects with the customer, the agent can perform all call control operations that are normally supported on inbound calls (transfer, conference, hold, retrieve, and so on). Cisco recommends that the agent transfers or conferences the outbound call only if the call is answered by a person but not through other media such as an answering machine or a fax machine.

Behavior under High Availability

The CDS is required for normal operation of Outbound for call status and call result updates of contact records. When deploying in a 2-nodes high availability system, the CDS must be running on both nodes to enable the database write operation. If either CDS is down, then the Outbound Subsystem will not be operational.

The following events occur during a failover:

- If a reservation call is at the agent desktop waiting for the agent to accept the call, when the master engine goes down, the agent is automatically logged out and the reservation call disappears from the agent desktop. If the master engine restarts during failover, the call status for that contact record is set to unknown. If the master engine does not restart during failover, the contact is called when the campaign starts and there are available agents.

- If a reservation call has been accepted by the agent and the call is ringing on the customer phone, there is no effect on the call. However, the agent is logged off and will be able to invoke call control capabilities only through the phone.

When deploying Outbound in a high availability environment, only the dialer in the master node is active. Therefore, even though you have two dialers in the system, outbound calls cannot be distributed or load balanced between the Dialers.

Scalability

Outbound supports different capacities and limits when compared to inbound agents. Refer the Configuration and Ordering Tool for more details.

Call Flow Description—Direct Preview Mode

In the direct preview mode, the agent hears the ring-out on the agent phone. The direct preview call flow proceeds as illustrated in Figure 2-4 and the description that follows.

Figure 2-4 Call Flow for Direct Preview Mode

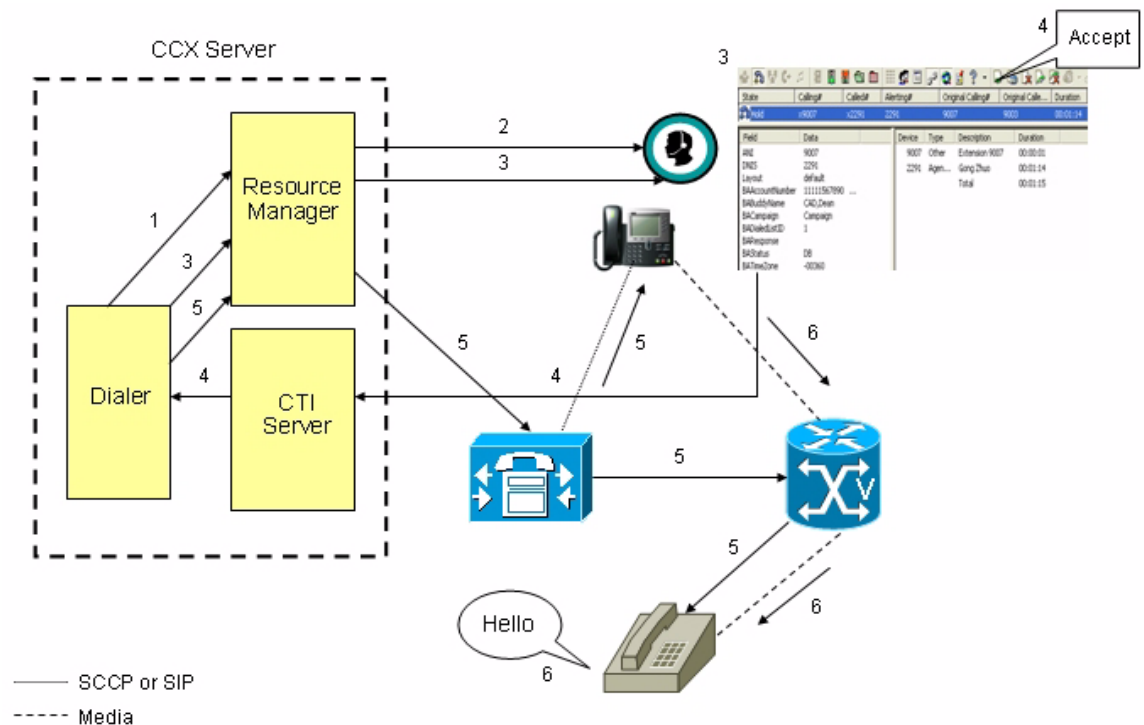

1. An agent in READY state is available and the Dialer has retrieved contact records from the Campaign Manager. The Dialer requests the Resource Manager to reserve the agent.
2. The Resource Manager reserves the agent by moving the agent to Reserved state.
3. The Dialer sends a reservation call to the agent desktop and at the same time, a screen pops that contains the customer information is presented to the agent. The agent reviews the customer data and decides whether to take the call.

4. The agent can choose to accept, skip, reject, or cancel this reservation call. If the agent chooses to accept it, the agent clicks Accept button on the desktop.
5. The Dialer instructs the Resource Manager to place an outbound call from the agent phone via Cisco Unified CM out to the voice gateway. Because this call is a direct preview call, the agent immediately hears the ringback of the customer phone.



Note Note that no CTI Port is needed to place the outbound call.

6. As soon as the call is answered, the Dialer closes the contact, classifies it as a voice call and sends the result to the Campaign Manager. If an answering machine answers the call, the number is invalid, or the customer requests a callback, and the agent can reclassify the call from the desktop accordingly. If the customer requests a callback and the agent reclassifies the call, the customer is called back using the same number, an alternate number, or a callback number specified by the customer.

Deployment Guidelines

The following guidelines should be followed when deploying Outbound:

- Outbound supports a maximum of 15 campaigns, a maximum of 10 CSQs for each campaign, and a maximum of 10,000 active outbound records for each campaign.
- Only CAD agents are supported. IPPA are not supported.
- Outbound cannot detect an answering machine, fax, or modem. The agent should manually reclassify the call to “answer machine” or “fax” from the desktop. The contact will be called again using the same number in the case of “answer machine” or using an alternate number in the case of “fax.”.
- Agent should not transfer or conference the outbound call if the call is answered by the media other than a person, such as an answering machine or fax machine.
- All macros and automatically invoked workflows configured for the agent desktop are disabled during and outbound call.
- Outbound does not come pre-installed with any US National Do Not Call lists. The system administrator should manually filter the contact list against the Do Not Call list prior to importing contacts.

Cisco Interaction Manager

Cisco Unified CCX can be integrated with Cisco Interaction Manager to provide multichannel capabilities and allow agents to handle e-mail, chat, and basic web collaboration sessions in addition to voice calls. Cisco Interaction Manager is a shared platform that contains Cisco Unified E-mail Interaction Manager (Cisco Unified EIM) and Cisco Unified Web Interaction Manager (Cisco Unified WIM). Cisco Unified EIM provides sophisticated e-mail management capabilities and Cisco Unified WIM provides high-value live assistance to online customers and prospects through text chat and web collaboration (page-pushing through URL sharing).

Web collaboration is available through chat sessions. E-mail and chat/web collaboration activities are handled by agents through the CAD embedded browser or a separate browser. Voice activities are handled as usual through the CAD desktop or through IPPA.

Universal queuing is not supported with Cisco Unified CCX and Cisco Interaction Manager integration. The queues for voice, e-mail, and chat/web collaboration are independent. The agent states Ready and Not Ready for voice, e-mail, and chat/web collaboration are also independent. Therefore, if an agent state is set to Ready for voice, e-mail, and chat/web collaboration, this agent could be assigned to all these activities simultaneously. When handling one of these activities, an agent could manually change state to Not Ready for the other types of activities to avoid this situation.

When integrating Cisco Interaction Manager with Cisco Unified CCX, the following data is automatically downloaded from Cisco Unified CCX to Cisco Interaction Manager

- CSQs (referred as queue in Cisco Interaction Manager), agents, and supervisors configurations
- Teams (referred as User Group in Cisco Interaction Manager) information

If some of this data is modified in Cisco Unified CCX, the change will be automatically propagated to Cisco Interaction Manager.

Some multichannel historical reports are integrated with voice historical reports and are available through the Cisco Unified CCX Historical Report Client. For example, these reports are the Multichannel Agent Contact Summary Report, the Multichannel Agent Login Logout Activity Report, and the Multichannel CSQ Activity Report. For these reports, the Historical Reporting Client queries the Cisco Unified CCX database, which in turn queries the Cisco Interaction Manager database to obtain information about the multichannel activities. Other detailed Cisco Interaction Manager historical reports are available directly through the Cisco Interaction Manager interface.

The guidelines to follow when deploying Cisco Interaction Manager with Cisco Unified CCX are:

- Cisco Unified CCX and Cisco Interaction Manager must be installed on separate servers.
- Cisco Interaction Manager can be deployed on a single server or on multiple servers for larger deployments. For more details, refer to the Cisco Interaction Manager SRND for Cisco Unified CCX available at the link:
http://www.cisco.com/en/US/products/ps7233/products_implementation_design_guides_list.html
- A Cisco Interaction Manager deployment can be integrated with only one Cisco Unified CCX cluster.
- A Cisco Unified CCX cluster can be integrated with only one Cisco Interaction Manager deployment.
- Cisco Interaction Manager can be integrated with a Cisco Unified CCX HA deployment. If a Cisco Unified CCX engine fails, Cisco Interaction Manager connects to the redundant Cisco Unified CCX engine, if available.
- The Cisco Interaction Manager servers must be located in the same campus LAN as the Cisco Unified CCX servers. The maximum round-trip delay between the Cisco Interaction Manager servers and the Cisco Unified CCX servers should be less than 5 ms.

Cisco Unified CCX Agent E-Mail

As part of the Premium offering, Cisco Unified CCX agents can service customer e-mails using the CAD interface. This capability does not exist with Cisco Agent Desktop- Browser Edition.

CSD includes real-time displays and information that enable supervisors to manage e-mail CSQs and their e-mail capable agents. When creating a CSQ in Cisco Unified CCX Administration, you designate the CSQ as either e-mail or voice. A single CSQ cannot be both an e-mail CSQ and a voice CSQ. Agent association with e-mail CSQs is done in the same manner as voice CSQs.

The agent states READY and NOT READY for e-mail and voice are independent of each other. An agent can handle both e-mails and voice calls simultaneously. An agent can receive e-mails only if he manually moves himself to e-mail READY state. Only agents that have been assigned to at least one e-mail CSQ will see the e-mail functionality in CAD. Likewise with supervisors; only supervisors that service a team with at least one e-mail capable agent will see the e-mail functionality in CSD.

The Agent E-Mail feature requires the use of an external mail store (Microsoft Exchange 2003 and 2007 are supported). This mail store is not provided, installed, or configured as part of the CAD installation.

Agent E-Mail uses the IMAPv4 (for message retrieval) and SMTP protocols (for message sending). These protocol types must be enabled in Microsoft Exchange and host/IP information must be specified using Cisco Desktop Administrator. These protocol types are not typically enabled by default. CAD and the Cisco Desktop Agent E-Mail Service make IMAP connections to the mail store. Cisco Desktop Agent E-Mail Service also makes an SMTP connection to the mail store. Agent E-Mail supports both secure and plain text connections to the mail store.

CAD components (Cisco Agent Desktop and Cisco Desktop Agent E-Mail Service) will connect to the mail store using a single dedicated mail store account. This account must be created by the mail store administrator. CAD must be configured to use this account via Cisco Desktop Administrator. This account should be a dedicated account, and not used for purposes other than the Agent E-Mail feature.

While CAD uses a single e-mail account, it can, and typically will, have multiple distribution list addresses associated with that user. This e-mail account and corresponding distribution lists must be configured manually by the mail store administrator. Routing information for the distribution list addresses can then be specified using Cisco Desktop Administrator.

**Note**

Microsoft Exchange allows you to associate multiple e-mail addresses with an e-mail account. Administrators may be tempted to use this feature instead of distribution lists. However, Microsoft Exchange may rewrite the To: address in the incoming e-mail to the primary address of the account, which then causes the Agent E-Mail feature to be unable to properly route e-mails to agents.

Figure 2-5 Cisco Unified CCX Agent E-Mail Components and Interfaces

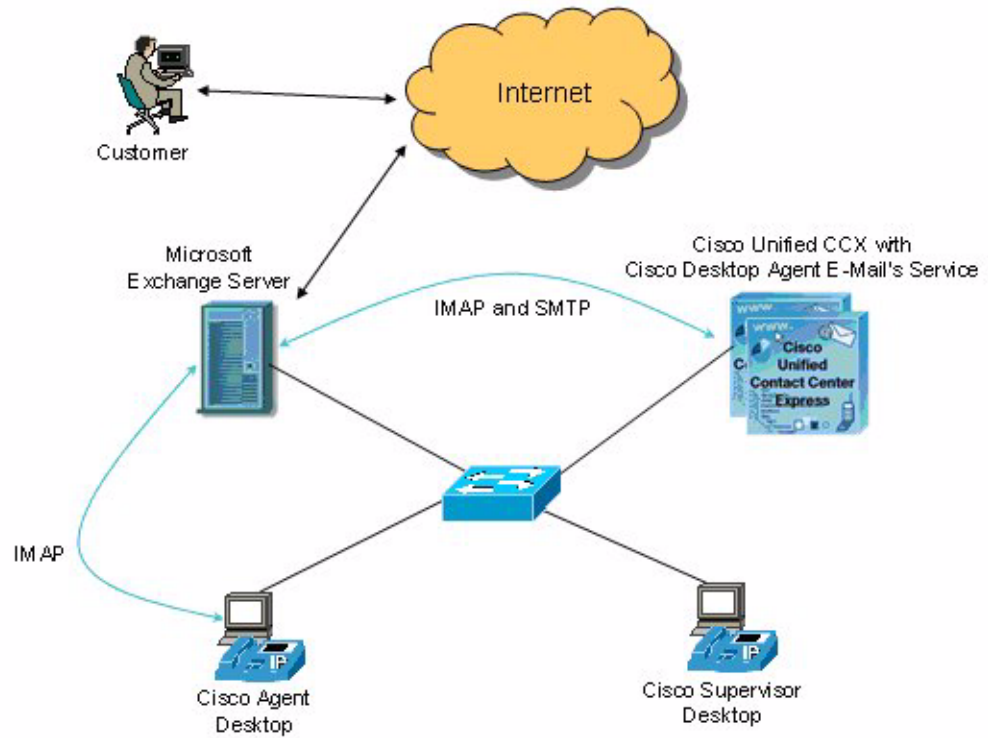

The following steps describe how an e-mail is routed using the Agent E-Mail feature:

1. The Cisco Desktop Agent E-Mail Service on the Cisco Unified CCX server connects to the mail store (IMAP and SMTP) on startup.
2. An e-mail capable agent in the E-Mail CSQ logs in using CAD. CAD connects to the Cisco Desktop Agent E-Mail Service and to the mail store (IMAP).
3. The agent goes to an e-mail ready state. CAD requests an e-mail from the Cisco Desktop Agent E-Mail Service.
4. A customer sends an e-mail to, for example, sales@companyname.com.
5. sales@companyname.com is a distribution list with Agent E-Mail's account as the only member. Microsoft Exchange presents the e-mail to that account's inbox.
6. The Cisco Desktop Agent E-Mail Service has been monitoring the Agent E-Mail's account inbox, and sees the new e-mail. Based on the routing rules specified in Cisco Desktop Administrator, it sees that e-mails to sales@companyname.com are associated with the E-Mail CSQ and that an agent in the E-Mail CSQ is in the ready state. The service then assigns the e-mail to the agent and notifies the agent.
7. CAD receives notification of the assignment and retrieves the e-mail from the mail store directly.
8. The agent is presented with the e-mail from the customer.
9. The agent authors a response and presses the "Send" button.
10. The agent's response is saved to the outbox folder on the mail store using IMAP commands.

11. The Cisco Desktop Agent E-Mail Service periodically checks the outbox folder and sends all messages in it.

**Note**

Ensure that the anti-virus software installed in Cisco Unified CCX server does not block the SMTP operation performed by the Cisco Desktop Agent E-Mail Service to send outgoing e-mails. Refer the *Cisco Agent Desktop User Guide* for details on which process to unblock.

Cisco Agent Desktop Integration with Cisco Unified Presence

CAD agents and supervisors have long been able to communicate with each other via the chat services built into the desktop applications. If you have deployed Cisco Unified Presence in their environments, agents and supervisors can use these same desktop applications to see the presence status of SMEs as well as other critical members of the enterprise, and to initiate chat sessions with them. The SMEs use the Cisco Unified Personal Communicator or IP Phone Messenger to initiate chat sessions with agents who are configured as Cisco Unified Presence users and respond to the chat requests from them. SMEs can also use Microsoft Office Communicator if Cisco Unified Presence is configured to support federated users. The Cisco Unified Presence integration feature is available in the Standard, Enhanced, and Premium packages.

For example, a customer calls a Cisco Unified Contact Center that has integrated Cisco Unified Presence with CAD. The customer's call is routed to an available agent. If the agent requires assistance in addressing the caller's needs, the agent can launch the contact selection window from the Agent Desktop toolbar. The contact selection window will display the presence status of other agents, supervisors, and SMEs who are assigned to the agent's work flow group. The agent can then select a contact who is available and initiate a chat session with the contact. If appropriate, the agent can also use the contact selection window to conference a contact into the call, or even transfer the customer's call to the contact.

[Figure 2-6](#) and the description that follows describe how various components of Cisco Agent Desktop and Cisco Unified Presence interface with each other.

Figure 2-6 Interface between Cisco Agent Desktop and Cisco Unified Presence

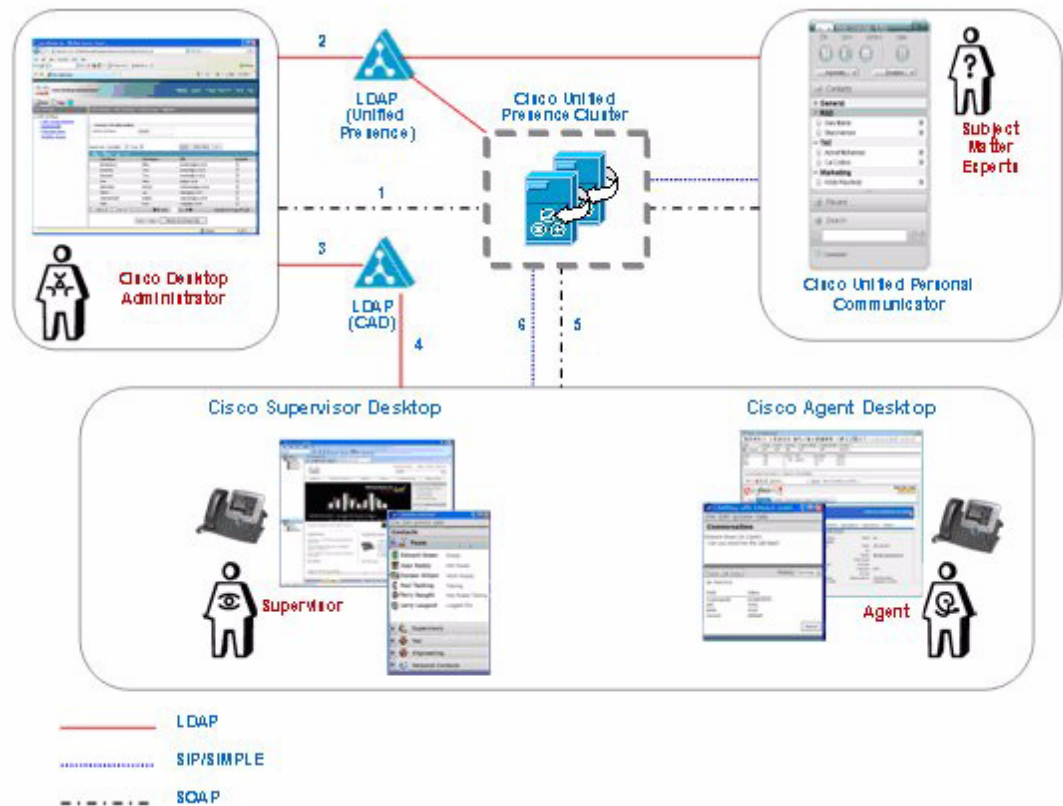

1. Cisco Desktop Administrator retrieves LDAP configuration profile through the SOAP Interface.
2. Cisco Desktop Administrator binds to the LDAP server for SME searches and information, such as name and telephone number.
3. Administrator places SMEs in logical groups called contact lists and then assigns them to specific work flow groups. This way, Administrators can segment contact lists and ensure that only those agents assigned to a specific work flow group have visibility to the appropriate contact list. This configuration is saved in CAD's LDAP so that each agent/supervisor does not have to access the Unified Presence's LDAP server which might have limitations on number of connections, etc. Administrators can also control the SMEs ability to see the agent's present state.
4. CAD retrieves contact list associated with the agent's workflow group.
5. CAD retrieves various configuration profiles via the SOAP interface, for example, Unified Presence server information.
6. CAD sends a SIP REGISTER to register with Cisco Unified Presence, followed by individual SIP SUBSCRIBE messages for each user in its contact list. CAD also sends a SIP SUBSCRIBE for "user-contacts" for contacts configured on Cisco Unified Presence. A SIP NOTIFY is received whenever a contact in the contact list changes state. CAD does not allow agents to change their presence states. It only sends a single SIP PUBLISH message to Cisco Unified Presence when agent logs in.

Call Control is done via the existing CAD main window using CTI. All SIP traffic and presence information sent between CAD and Cisco Unified Presence is not encrypted and is done via TCP or UDP.

In Cisco Unified Presence 7.x, Cisco Unified Presence can evenly assign the users registered with it across all nodes within the Cisco Unified Presence cluster. If the user attempts to connect to a node that is not assigned to him, CAD will connect to the SOAP and Presence servers specified in redirect messages from the publisher.

All communication between CAD agents and SMEs is via the Cisco Unified Presence server and is not routed through any CAD server. Refer the chapter on Cisco Unified Presence in the *Cisco Unified Communications SRND* for deployment guidelines.

Agent Phones in Countries with Toll-Bypass Regulations

Some countries such as India have telecommunications regulations that require the voice infrastructure to be partitioned logically into two systems: one for Closed User Group (CUG) or Voice over IP (VoIP) to enable communications across the boundaries within the organization, and a second one to access the local PSTN. To ensure adherence of the regulations in such countries, agents typically used to have only one line with access to customer calls only, and they were required to have a different phone (for example, a softphone) to access a VoIP line for contacting fellow teammates or experts located outside the contact center.

The Logical Partitioning feature in Cisco Unified CM provides the same capability through a telephony system to control calls and features on the basis of specific allowed or forbidden configurations. A common telephony system in a contact center environment can provide access to both the PSTN and VoIP networks, therefore configurations are required to provide controlled access and to avoid toll bypass. The Logical Partitioning feature can be enabled and configured in Unified CM to prevent toll bypass calls, thus allowing agents in a Unified CCX system to use the same phone for receiving customer calls and for making or receiving VoIP calls to and from other people within the organization. Although this eliminates the need for agents to have a second phone, contact center managers can choose to have a dedicated line or phone for customer calls and allocate a different line or phone for other calls.

Cisco Unified Workforce Optimization

Cisco Unified Workforce Optimization (WFO) for Cisco Unified CCX is a full-featured solution for optimizing performance and quality and is an integral component of the Cisco Unified Communications System. WFO suite provides these solutions:

- Workforce Management (WFM)—Allows for forecasting and development of schedules for agents across multiple sites and channels. It also provides real time dashboards enabling supervisors to track key performance indicators, and manage agent's adherence to schedules.
- Quality Management (QM)—A voice and screen recording, compliance and evaluation solution for agent performance optimization and dispute resolution.

Figure 2-7 shows the overall service communications medium between the WFO solutions and the Cisco Unified CCX system.

Figure 2-7 Service Communications Medium Between WFO solutions and Cisco Unified CCX

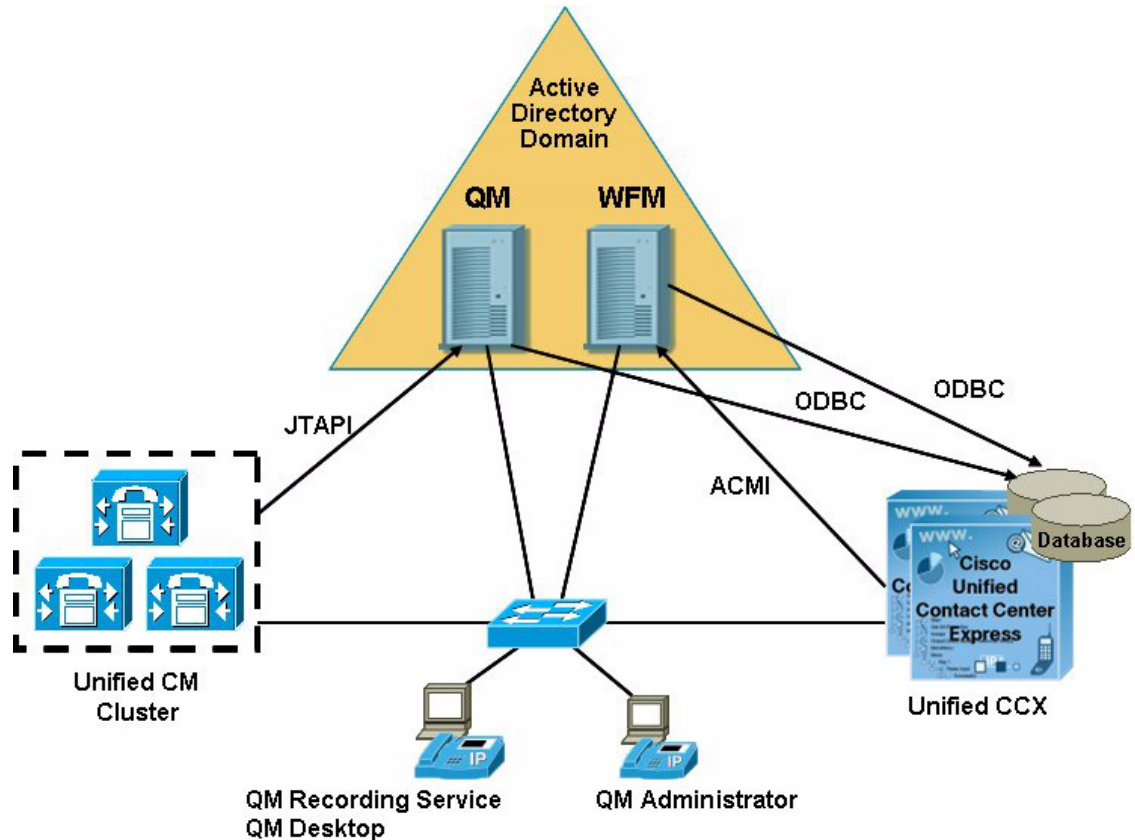

Figure 2-7 illustrates a couple of integration points between the WFO solutions and Cisco Unified CCX system.

- Workforce Management - Uses the ACMI link to monitor agent's adherence to the schedules. It uses the ODBC link to download the historical data from Cisco Unified CCX database to generate the forecasting data.
- Quality Management - Uses JTAPI to monitor the call progress on the agent phone so that it knows when to start and stop the voice recording. It uses the ODBC link to download the agent, supervisor and team configuration data from Cisco Unified CCX database.

For more details on components architecture, deployment configuration and sizing, refer the *Cisco Workforce Optimization System Configuration Guide* available at the link:

http://www.cisco.com/en/US/products/ps8293/products_implementation_design_guides_list.html

Cisco Unified CCX ASR and TTS

Cisco Unified CCX allows integration with Media Resource Control Protocol (MRCP) compliant Automatic Speech Recognition (ASR) and Text-To-Speech (TTS) servers. Nuance, Scansoft, and IBM are the only ASR and TTS providers that have been tested and will be supported. ASR and TTS software must be purchased from one of these vendors. These vendors can provide design and server sizing requirements for their software. Cisco no longer resells Nuance ASR and TTS as a Cisco Unified CCX option.

From Cisco Unified CCX Administration, you must configure the address of an MRCP server and the number and type of resources provided by that MRCP server. Multiple Cisco Unified CCX clusters can interact with the same MRCP servers. Multiple Cisco Unified CCX servers can interact with the same MRCP servers. A Cisco Unified CCX server can also define multiple MRCP servers, and resources from those servers are selected based upon the system and application configuration.

Calls requiring ASR require the Cisco Unified CCX Engine to pass the media stream from the CTI port to the ASR Server. This activity impacts system performance and system sizing. The impact is reflected in the Cisco Unified CCX 7.0 Configuration and Ordering Tool.

When using ASR, the ASR resource is allocated at the time of the first step that uses ASR. The ASR resource is then allocated for the duration of the call. When using ASR, you must calculate the required number of ASR resources (ports) similar to the way you calculate any IVR port requirement. You will need the average time the ASR port is used (similar to average call treatment time) and the number of calls using ASR in the busy hour. You can then input this data into any Erlang-B traffic calculator or other tool to compute the number of ASR resources required. In environments where you have long queue times, it might be economical to transfer the call to another CTI Route Point and pass call data to the second application (via session data steps) in order to allow the ASR resource to be released.

For TTS, each 'Generate TTS Prompt' allocates and releases a TTS resource, and the TTS resource is typically only allocated for a couple of seconds and then released (this might vary depending on the application). To determine the number of TTS resources, use the same methodology described above for ASR resources.

Cisco Unified CCX Integration with Unified ICME Software

Cisco Unified CCX can also be implemented as a child ACD of Cisco Unified Intelligent Contact Management Enterprise (Cisco Unified ICME) 7.x software. The Cisco Unified CCX integration with Cisco Unified ICME software requires a Unified CCX Gateway PG process to be co-resident on the Cisco Unified CCX. This integration provides the following capabilities:

- The ability for Cisco Unified CCX to send agent, queue, and call state changes to the Cisco Unified ICME.
- The ability for Cisco Unified ICME software to intelligently route and load balance calls across multiple ACD sites which can include one or more Cisco Unified CCX systems, Cisco Unified Contact Center Enterprise (Unified CCE) systems, or traditional ACDs (that are supported by Cisco Unified ICME software). Calls routed to a Cisco Unified CCX application can also be sent call data so that it can be popped onto an agent's screen.
- The ability for Cisco Unified CCX to send post-route requests with call data to the Cisco Unified ICME in order to request intelligent routing instruction. This could be in response to a transfer request from an agent or from a step within and Cisco Unified CCX application running on a CTI port.
- The ability for ICM software to provide multi-site ACD reporting for a mixed network of ACD sites which can include one or more Cisco Unified CCX systems, Unified Contact Center Enterprise systems, or traditional ACD's.
- The ability for Cisco Unified CCX to send post-route requests with call data to the Cisco Unified ICME software in order to request routing instructions. This could be in response to a new call that just arrived at Cisco Unified CCX or a call that is being transferred from an IVR port or agent. Call data included in the post-route request can be used by the Cisco Unified ICME software to profile route the call, and call data is also passed to the terminating ACD site (Cisco Unified CCX, Cisco Unified CCE, or traditional ACD) for an agent screen pop.

**Note**

This parent/child deployment is not supported when Cisco Unified CCX is integrated with Cisco Unified CME.

Figure 2-8 shows one Cisco Unified ICME integration deployment scenario. In this scenario, the Cisco Unified ICME routes and load balances calls between two Cisco Unified CCX 7.0 deployments. A separate deployment of Cisco Unified IP IVR's is also included to demonstrate how additional IVR capacity (beyond 300 IVR ports) could be added to a Cisco Unified CCX 7.0 deployment. The IVR PG allows call data from IVR applications to be passed to Cisco Unified CCX agents at either site. The IVR PG could also connect traditional IVR's (that are supported by the Cisco Unified ICME) to allow an organization that has existing IVR applications to continue using those IVR applications.

Figure 2-8 Unified CCX Gateway Solution with Two Cisco Unified CCX Sites

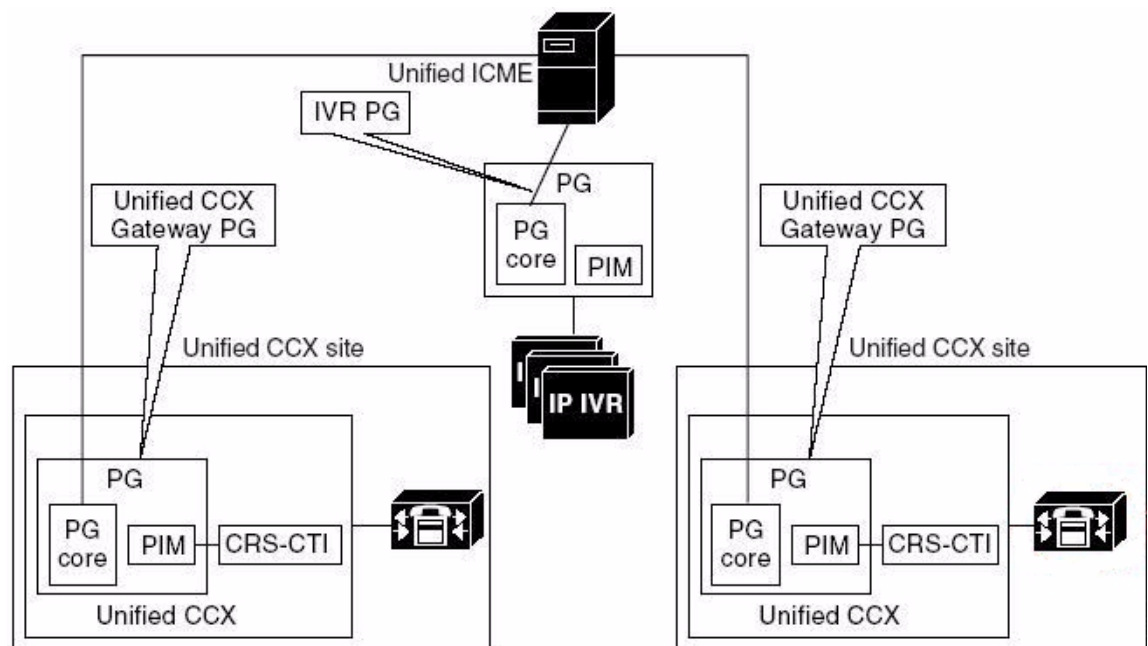
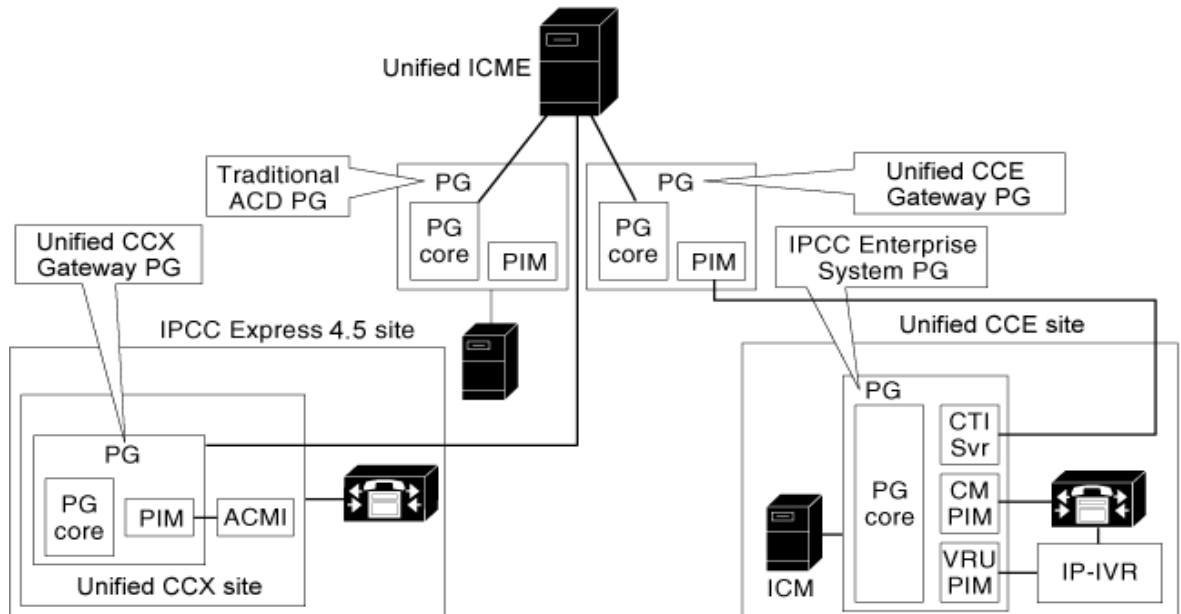

Figure 2-9 shows another Cisco Unified ICME integration deployment scenario. In this scenario, the Cisco Unified ICME routes and load balances calls between a Cisco Unified CCX 7.0 site, a Cisco Unified CCE 7.x site, and a traditional ACD site. Call data for agent screen pop can be passed between these sites via the Cisco Unified ICM.

Figure 2-9 Cisco Unified ICME Integration with Two Unified Gateway Sites and one Traditional ACD Site



For Cisco Unified CCX to integrate with Cisco Unified ICME software, there must be a Cisco Unified CCX Gateway PG installed on the Cisco Unified CCX server. It is not supported for the Cisco Unified CCX Gateway PG to run on a separate server when integrating Cisco Unified CCX with the Cisco Unified ICME software.

The Cisco Unified CCX Gateway PG must be ordered as a part of the Cisco Unified ICME 7.x software suite. The Cisco Unified CCX Gateway PG software is installed from the Cisco Unified ICME software installation CD—not from the Cisco Unified CCX software CD.



Note

Partners must have Cisco Unified ICME/Unified CCE ATP status to order and deploy the Cisco Unified Gateway PG with Cisco Unified ICME software.

Running the Cisco Unified Gateway PG might reduce the maximum supported number of agents and call processing capabilities of a Cisco Unified CCX deployment. The Cisco Unified CCX 7.0 Configuration and Ordering Tool can assist solution planners and designers in sizing the hardware required for a Cisco Unified CCX deployment.

When the Cisco Unified ICME routes calls to Cisco Unified CCX, it is really routing them to a Cisco Unified CM dialed number. Then Cisco Unified CM goes through the process of resolving the dialed number association to the CTI Route Point and Cisco Unified CM Telephony user and offering the call to Cisco Unified CCX. Cisco Unified CCX then invokes the appropriate script.

For more information about the Cisco Unified CCX Gateway, see the *Cisco Unified Gateway Deployment Guide*.

Cisco Unified CCX Fault Tolerance

The Cisco Unified CCX solution offers a number of capabilities to provide fault tolerance. To begin with, a Cisco Unified CCX deployment utilizes a Cisco Unified Communications network composed of Cisco data switches and routers, which provide for a highly available data network with many options for redundancy. Cisco campus and network design guides discuss best practices for designing highly available networks with Cisco switches and routers.

A Cisco Unified CM deployment utilizes a cluster approach with up to eight call processing servers per Cisco Unified CM cluster. Cisco Unified CM groups devices (voice gateways, IP Phones, and CTI Ports) into device pools and allows for device pools to have a primary, secondary, and tertiary Cisco Unified CM server. When a device pool's primary Cisco Unified CM server fails, the devices within that device pool automatically fail over to the secondary or tertiary Cisco Unified CM server. Unified CCX CTI Ports are grouped together into CTI call control groups (often called a CTI port group). Each CTI port group is configured as part of a device pool. Cisco Unified CM also supports voice gateways deployed at many locations with trunks from different service providers.

Cisco Unified CM has a subsystem called the CTI Manager that abstracts the device management from the JTAPI communications to an application server (like Cisco Unified CCX). This implementation allows an application to not be concerned with what specific server a device (voice gateway, agent phone, or CTI port) is currently registered. Cisco Unified CCX has the ability to communicate with up to two CTI Managers within a Cisco Unified CM cluster, but only actively communicates with one at a time. If the active CTI Manager subsystem or the Cisco Unified CM node running the active CTI Manager fails, Cisco Unified CCX closes the sockets for all CTI ports and immediately begins JTAPI communications with the backup CTI Manager. Calls being handled by agents survive, but if their phones are registered with the failed Cisco Unified CM, they will not be able to perform any subsequent call control. Upon completion of existing calls, agent phones will automatically re-register to the secondary Cisco Unified CM server. For agents who were not off hook, their phones will re-register to the secondary Cisco Unified CM immediately.

In addition to being able to fail over to another Cisco Unified CM node within the cluster, Cisco Unified CCX itself provides a clustering mechanism. In a high availability deployment, up to two servers can be deployed, each server configured with the Cisco Unified CCX Engine and Database components with the optional, Monitoring and Recording components.

The four components all provide some level of redundancy and fault tolerance, but each functions a bit differently.

Cisco Unified CCX Engine Redundancy

When deploying with high availability, two Cisco Unified CCX Engine components must be deployed on separate servers. If one server initiates the engine mastership election first, it becomes master. The other server becomes standby. If both servers are started approximately at the same time, it is not specified which server becomes master. If the Cisco Unified CCX Engine component server fails over, the standby server becomes the master server and remains as the master server until another failure occurs. Any active calls being processed by applications on CTI Ports will be released upon failure of the master Cisco Unified CCX Engine server.

All ACD, IVR, and desktop services will failover within 5 seconds. Any incoming call arriving at Cisco Unified CM destined for Cisco Unified CCX route points can be accepted by the Cisco Unified CCX engine and all Cisco Unified CCX call treatment and ACD routing services are operational.

Automatically logging on large numbers of agents may take up to 1 minute. For a given agent, the ACD is not able to route calls to agents until the automatic login process completes and the agent manually sets the state to Ready. Agents on Cisco Unified CCX routed calls will see those calls survive and CAD

will automatically relog agents back in within one minute, and they will see a visual indicator that a failover has occurred. After being logged back in, agents will have to set the state to 'Ready' when they are ready to begin receiving calls. Agents using IPPA will need to manually log in to the new master Cisco Unified CCX Engine server.

**Note**

Historical Report generation is done by giving preference to non-Engine master node so that generation of Historical Reports does not affect the Cisco Unified CCX Engine performance. In a two-node scenario where the Engine Master is on the Database Publisher node, the historical reports are generated on the database subscriber node. If the Engine master fails over to the database subscriber node, the historical reports are generated on the database publisher node. Therefore, in a deployment with high availability and with both Cisco Unified CCX servers running, the maximum number of historical reporting sessions that is supported during normal operating hours is higher. If a server fails, this number reverts to the limit in a deployment without high availability. Note that this support for higher number of historical reporting sessions in a high availability deployment only applies to newer platforms. Refer the Configuration and Ordering Tool for the limits on each platform.

Database Redundancy

When deploying with high availability, for Historical Data store, Agent Data store, and Repository Data store, the two servers running the Database components are set up with one being the publisher and one being the subscriber. These roles do not change in the event of a failure. If both the publisher and the subscriber are up and running, the server running the Publisher Database component is given DB mastership, where data is written to and read from. If the server running the Publisher Database component is down (or any of the SQL Services such as MSSQL\$CRSSQL, Distributed Transaction Coordinator or SQL Agent\$CRSSQL on the server with the Publisher Database is down), the subscriber is given the DB mastership, where data is written to and read from. SQL Merge Replication replicates the data between the publisher and subscriber. If the subscriber or publisher is down for less than the retention period (default is 4 days), replication will automatically kick-in to sync data from the publisher when the subscriber comes back in service and vice versa. If the subscriber is down for more than the retention period, the Subscriber has to be reinitialized at off-peak hours from the Cisco Unified CCX Administration Datastore Control Center page.

Under normal call load volume, a latency of 1 to 3 minutes for SQL Merge Replication is expected; this period could be higher for higher call load. The affect could be more when historical reports are running as it affects the SQL processing. Due to replication latency, the historical reports that are generated from a subscriber might not have the latest call records; the Historical Reports will be generated up to the last replicated time.

SQL Server *linked server* technique is used to replicate Configuration Data Store data in high availability deployments. The way it works is that when both servers with Databases components are operational, configuration data store changes, such as skills and resource groups, are written to both the servers with Database components. If one server with a Database component is down, configuration data store changes are not possible. However, configurations can be read in Cisco Unified CCX Administration; that is, no configuration data store data writes are possible, but data reads are possible when one server with a Database component is down. However, call processing, historical data writing, and call activity reporting can continue even when one Database component is down.

In the case where one of the Database servers is not operational and configuration data store changes are required, you can temporarily deactivate the configuration data store component on the off-line Database component server using Cisco Unified CCX Administration. After that, you can make configuration data

store changes on the active Database server. Once the off-line Database server is back in service, you can activate the configuration data store component on that Database server during off-peak hours as the whole active database configuration data store data will get synchronized.

Network Partitioning

When the network is partitioned (split into two or more islands), every island elects its own set of masters. When the partition is restored, all masters are dropped; therefore all calls receiving call treatment or in queue are dropped, and a new election process is initiated. As a result of this new election, the Database Publisher is elected as a master for the ADS, RDS, and HDS. It is not specified which Engine or CDS becomes the master.

Monitoring and Recording Redundancy

The Monitoring component is automatically installed on the Cisco Unified CCX server and should be activated to enable agent monitoring. When deploying with high availability and agent monitoring, the Monitoring components on each server should be activated. The two servers running the Monitoring service are sometimes considered as one *monitoring domain*. When configuring a phone with SPAN port monitoring, only one SPAN port monitoring server can be assigned to this phone.

When desktop monitoring is configured, CAD forwards the RTP stream to CSD. A server running the Monitoring component is still required for CAD to retrieve the agent phone's MAC address from the Cisco Unified CM. Any one of the two monitoring servers could be chosen for this purpose. If one Monitoring components fail, desktop monitoring still works, as long as the other server running the Monitoring component is still available in the Cisco Unified CCX cluster. It is possible to configure and enable both SPAN port monitoring and desktop monitoring for a phone. However, only one method is used at any time for that phone. If both SPAN port monitoring and desktop monitoring are configured correctly, desktop monitoring is chosen. If desktop monitoring fails, SPAN port monitoring is used as a backup. Refer the *Cisco Desktop Administrator User's Guide* for more information.

When deploying with high availability and agent call recording, the Recording components on each server must be activated. The two physical recording servers work as a single logical recording server (a *recording domain*) and recording tasks are load balanced in a round robin fashion across the two physical Recording Servers. A Cisco Unified CCX deployment only supports one recording domain. The actual call recordings are stored only on the disk of the physical Recording component server where the recording task took place. Therefore, if a recording server fails, the supervisor will be unable to playback those recordings on the failed Recording server until that Recording server is operational again.

The two servers where the Recording components are running also serve as a backup for each other. To function properly during a period when one of the servers fails, the two Recording servers must be sized to be capable of supporting all recording for the Cisco Unified CCX cluster. For example, under normal operating conditions, a large call center may be set up to handle 16 recording sessions on each Recording component, for a total of 32 simultaneous call recordings. If either server with a Recording component fails, the other server processes all call recordings. In this failure scenario, make sure that the total number of call recordings does not exceed the server capacity that is shown in the Configuration and Ordering tool.

Recording requires a Monitoring component. When SPAN port monitoring is configured for silent monitoring, the SPAN port monitoring server forwards the RTP stream to the Recording component. If that SPAN port monitoring server fails, recording is not possible. When desktop monitoring is configured, the Monitoring component is still required in order for CAD to retrieve the agent phone's

MAC address from the Cisco Unified CM. Either of the two monitoring servers could be used for this purpose. If one Monitoring component fails, recording still works, as long as the other server running the Monitoring component is still available in the Cisco Unified CCX cluster.

Cold Standby Support

Cisco Unified CCX high availability requires that the Cisco Unified CCX Engine and Database components and the CTI Managers with which the Cisco Unified CCX servers communicate be located in the same campus LAN and that the maximum round-trip delay between these servers be less than 2 ms.

For disaster recovery deployments where the backup Cisco Unified CCX servers need to be in a different geographic location, Cisco Unified CCX high availability is therefore not supported. However, for this requirement, it is possible to deploy identically configured cold standby servers in the disaster recovery site. The cold standby servers and the corresponding primary servers should have the same IP addresses. These cold standby servers at the second site should be shut down while the primary servers are in service at the first site. If a disaster occurs and the primary site is down, the cold standby servers are turned on, restored, and become the active servers.

The cold standby servers can be restored using one of the following tools:

- Backup and Restore tool
- Ghost or similar imaging tool

Cold standby is supported for all Cisco Unified CCX deployment models that are described in [Chapter 4, “Cisco Unified Contact Center Express Deployment Models.”](#) For example, in the two-server high availability deployment model, two cold standby servers can be added on the disaster recovery site.

When deploying cold standby, the following rules apply:

- Use the Backup and Restore tool to backup the primary servers and restore the cold standby server. For information about this tool, refer the *Cisco Unified CCX Administration Guide*
OR
Use Ghost or similar imaging tool to take periodic snapshots of the primary servers and restore the cold standby servers from those snapshot images. The snapshot images should be uploaded to a central location accessible from both sites.
- The deployment in the disaster recovery site must be identical to the deployment in the primary site (same number of servers, same server type).
- The cold standby servers should be shut down if the primary servers are running, and vice versa.
- If the Backup and Restore tool is used to restore the cold standby servers, do not perform the Unified CM Telephony Synchronization at the end of the restore process. If Cisco Unified CM Publisher is down or inaccessible, the synchronization will fail because it needs access to the publisher to perform write operation to Cisco Unified CM database.
- The deployment at the disaster recovery site must follow the Cisco Unified CCX rules for design that are described in [Chapter 4, “Cisco Unified Contact Center Express Deployment Models.”](#) For example, when deploying with high availability at each site, the Cisco Unified CCX servers must be located in the same Campus LAN and the round-trip delay between these servers should be less than 2 ms.
- Once the image is restored, the Cisco Unified CCX servers at the disaster recovery site should have the same IP addresses and hostnames as their corresponding servers at the primary site. However, changing IP addresses on the Cisco Unified CCX servers is possible. In this case, follow the procedure described in *Cisco Unified CCX Administration Guide* to change the IP addresses of the Cisco Unified CCX servers. Also update every CAD and CSD desktop by running the postinstall.exe program at C:\Program Files\Cisco\Desktop\bin on the desktop PC.

- In the primary site, hostnames of Cisco Unified CM servers can be used in all Cisco Unified CCX configurations. These hostnames can be put into DNS or local hosts file of Cisco Unified CCX servers. When the cold standby servers are active, the local hosts file should be updated to contain all the Cisco Unified CM server hostnames used by Cisco Unified CCX but pointing to the local Cisco Unified CM server's IP.
- Alternatively, if IP addresses of Cisco Unified CM servers are configured in Cisco Unified CCX, modify the Cisco Unified CCX configuration to use the local Cisco Unified CM.
- After the image has been restored, it may be necessary to modify other Cisco Unified CCX configurations. For example, the appropriate region and location for the CTI ports may need to be reconfigured for proper CAC and codec negotiation. Note that if Cisco Unified CM Publisher is down or inaccessible, CTI Port and Route Point updates are not possible because the AXL service used by Cisco Unified CCX needs access to the publisher to perform write operation to Cisco Unified CM database.

Upgrading to Cisco Unified CCX 7.0

Cisco Unified CCX 7.0 supports software upgrade from previous versions. Refer the *Cisco Unified CCX Installation Guide* from the link below for compatible upgrade versions. If you wish to upgrade to 7.0 and add high availability, one additional physical server of equal performance as the existing server must be added.

There is a limitation on the database size based on system hardware size. For more details, refer the “Cisco Unified CCX Disk Space Usage” section in *Cisco Unified CCX Installation Guide* available at: http://www.cisco.com/en/US/products/sw/custcosw/ps1846/prod_installation_guides_list.html

In addition, the Pre-upgrade check tool, which can be downloaded from CCO, can be run to find out how much data can be migrated before upgrade. This tool can be found on the same web site as the Configuration and Ordering tool.

Cisco Unified CCX 7.0 Software Compatibility

Cisco Unified CCX software is dependent upon integration with many other software components, especially Cisco Unified CM. Make sure to check to ensure the Cisco Unified CCX release you are planning is supported with the Cisco Unified CM release for which this deployment is planned. The *Cisco Unified CCX Software and Hardware Compatibility Guide* is available at:

http://www.cisco.com/en/US/products/sw/custcosw/ps1846/products_device_support_tables_list.html



CHAPTER 3

Cisco Unified Contact Center Express Solution Architecture for Cisco Unified Communications Manager Express

Cisco Unified CCX for Cisco Unified Communications Manager Express (Cisco Unified CME) is a solution composed of many components. These components include Cisco Unified CCX software, Cisco Unified CME, Cisco routers, Cisco data switches, Cisco Voice Gateways and Cisco Unified IP Phones. Cisco Unified CCX software is part of the Cisco Unified CCX software platform running with Cisco Unified CME. Cisco Unified CCX provides software capabilities for both Cisco Unified CCX and Cisco Unified IP IVR. With Cisco Unified CME, Cisco Unified CCX can run either Cisco Unified CCX or Cisco Unified IP IVR package.

Cisco Unified CCX for Cisco Unified CME and Cisco Unified CCX for Cisco Unified Communications Manager (Cisco Unified CM) have the same solution architecture for the following:

- Cisco Unified CCX system management
- Cisco Unified Wireless IP Phone 7920 support
- Citrix and Microsoft Terminal Services support for CAD
- Remote Agent Over Broadband
- Cisco Unified CCX ASR and TTS
- Cisco Unified CCX Agent E-Mail

For detailed information about the Cisco Unified CM architecture, see [Chapter 2, “Cisco Unified Contact Center Express Solution Architecture for Cisco Unified Communications Manager.”](#)

Cisco Unified CCX for Cisco Unified CME does not support the following solution architecture:

- Session Initiation Protocol (SIP) phone as an agent phone
- Cisco Unified CCX Integration with Cisco Unified ICM Software
- Cisco Unified CCX Outbound Preview Dialer
- Cisco TelePresence Virtual Agent Solution
- Cisco Interaction Managers
- Cisco Agent Desktop Integration with Cisco Unified Presence
- Agent Phones in Countries with Toll-Bypass Regulations
- Cisco Unified Workforce Optimization

This chapter includes the following sections:

- [Architectural Overview, page 3-2](#)
- [Cisco Unified CCX Call Processing, page 3-3](#)
- [Cisco Unified CCX Engine and Database Components, page 3-4](#)
- [Cisco Unified CCX Fault Tolerance, page 3-5](#)

Architectural Overview

Cisco Unified CCX communicates with Cisco Unified CME using open standard Session Initiation Protocol (SIP) for call processing. When the Cisco Unified CCX Engine starts, the CME Telephony Subsystem sends a SIP REGISTER request to initiate communication with Cisco Unified CME. Thereafter, Cisco Unified CCX sends SIP REGISTER requests at a configurable interval to Cisco Unified CME to keep the communication link active.

When Cisco Unified CCX registers with Cisco Unified CME, a session server is created in Cisco Unified CME. Each device that is created for this Cisco Unified CCX is associated with the session server so that Cisco Unified CCX can only monitor its own set of devices.

Cisco Unified CME offers line monitoring and call monitoring. Cisco Unified CCX uses line monitoring to monitor the ACD line on an agent device and call monitoring to detect incoming call and keep track of the call on the line. Cisco Unified CME uses the SIP Presence package for line monitoring and the SIP Dialog package for call monitoring. In Cisco Unified CME, an ephone is a Cisco Unified IP Phone and an ephone-dn is the line on the Cisco Unified IP Phone. To configure an Cisco Unified IP Phone as an agent device, the line monitoring attribute on the ephone-dn of the ephone should be enabled. Using line monitoring and call monitoring, when an agent device goes on or off hook or a call is transferred to or out of the agent device, Cisco Unified CME notifies Cisco Unified CCX about the changes and Cisco Unified CCX can change the agent state accordingly.

In Cisco Unified CME, there is no concept of CTI ports. During the engine activation phase, a default call control group with the number of channels equal to the number of licensed ports is created automatically by the system. All CME telephony triggers will use this default call control group.

An agent is configured in Cisco Unified CCX as a user with agent capability and is stored in the Cisco Unified CCX database. An agent does not have an associated extension until the agent logs in successfully. Even though an agent has an assigned extension, the agent can log off and log in with a different extension. Thus, an agent can log in with multiple agent devices without using Extension Mobility.

**Note**

Cisco Unified CCX does not support Cisco Unified SRST or Cisco Unified CME running in SRST mode.

Cisco Unified CCX Call Processing

Figure 3-1 and the description that follows explain a typical inbound call flow in Cisco Unified CCX for Cisco Unified CME.

Figure 3-1 Cisco Unified CCX for Cisco Unified CME Inbound Call Flow

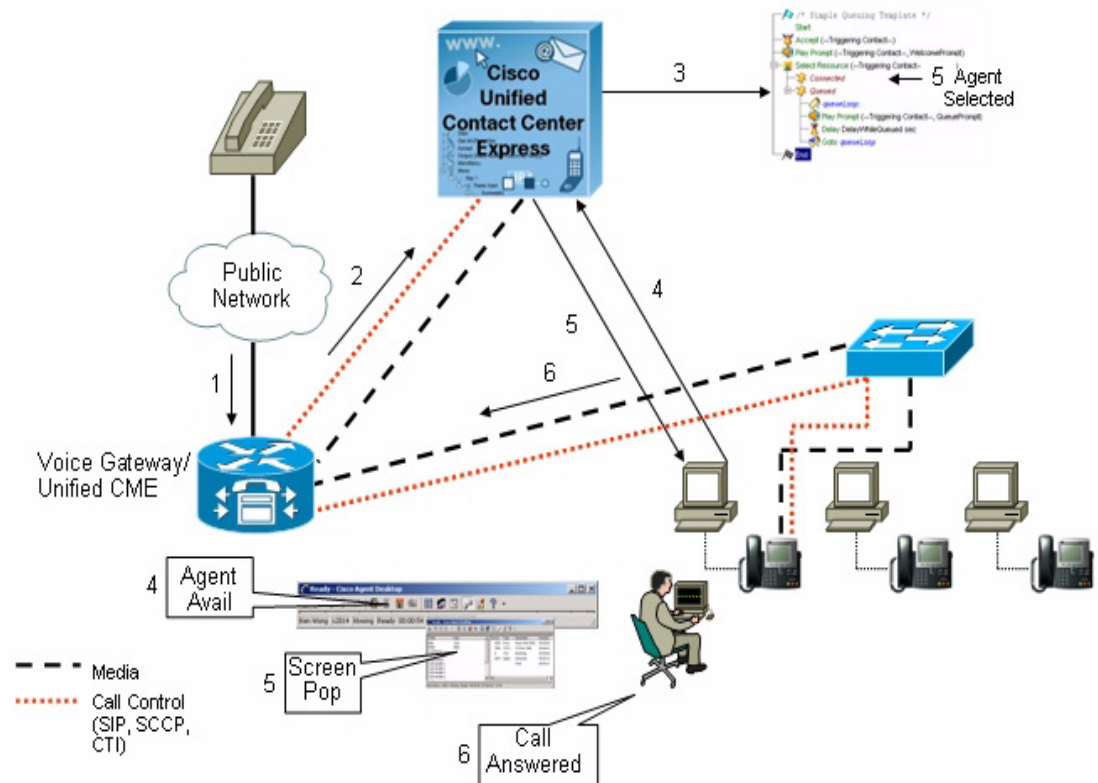

1. Call arrives at voice gateway, which is also a Cisco Unified CME.
2. Voice gateway asks Cisco Unified CME how to route the call through SIP. Cisco Unified CME has a dialed number (DN) that Cisco Unified CCX has subscribed for monitoring. Cisco Unified CME notifies Cisco Unified CCX about the call arrival on the DN.
3. Based upon the DN, Cisco Unified CCX finds an available channel from the default call control group to handle the call and then map the DN to the appropriate Cisco Unified CCX script. The script then answers the call and establishes a RTP stream between Cisco Unified CCX and Cisco Unified CME for media exchange. Then the caller is prompted to enter some information and wait for the next available agent. Assuming that there is no skilled agent available, the script executes the queued loop logic until an agent becomes available.
4. An agent becomes available as a result of logging in and going to Ready state or completing a customer call.
5. The agent is selected and reserved by Cisco Unified CCX server and the call is transferred to the agent phone. As a result, the agent phone rings. At the same time, a screen that contains the information entered by the caller pops up on the agent desktop.
6. Agent answers the call and an RTP stream is established between the agent phone and Cisco Unified CME for exchanging media

Cisco Unified CCX Engine and Database Components

Cisco Unified CCX for Cisco Unified CME includes these core software components:

- Cisco Unified CCX Engine
- Database
- Monitoring
- Recording

Every Cisco Unified CCX deployment must have the Cisco Unified CCX Engine and database components. The monitoring and recording components are optional and are discussed in the [“Monitoring and Recording Components” section on page 3-4](#). With Cisco Unified CCX for Cisco Unified CME, only one instance of each of these components can be installed and all components must be on the same physical server.

The Cisco Unified CCX Engine (with its closely related subsystems) is the component that provides functions such as the following:

- Telephony Interface with Cisco Unified CME
- Execution of scripts
- Encoding and streaming of .wav files (G.711 codec only)
- Communications with CAD for agent state control and screen pop
- Agent monitoring and selection
- Cisco Unified CCX Administration web interface.

You can think of the Cisco Unified CCX Engine component as providing the core ACD, IVR and CTI services. The other components—Database, Monitoring and Recording—are auxiliary software components.

The database component is a required component for any Cisco Unified CCX deployment. It manages access to the database. The Cisco Unified CCX Database contains these datastores:

- Configuration datastore (CDS)
- Repository datastore (RDS)
- Agent datastore (ADS)
- Historical datastore (HDS)

The configuration datastore contains Cisco Unified CCX configuration information such as resources (agents), skills, resource groups, teams, CSQ, applications, triggers, call control groups, and dialog groups. The repository datastore contains user prompts, grammars, and documents. The agent datastore contains agent logs, statistics, and pointers to the recording files. The historical datastore contains Contact Call Detail Records (CCDRs) and other data for historical report.

Monitoring and Recording Components

Cisco Unified CCX for Cisco Unified CME has the same solution architecture for SPAN port monitoring, desktop monitoring, and recording as Cisco Unified CCX for Cisco Unified CM. However, Cisco Unified CCX for Cisco Unified CME does not support:

- G.729 as the audio codec
- Remote supervisory monitor using an IP phone or PSTN phone.

See to the “[Monitoring and Recording Components](#)” section on page 2-6 for related architecture information.

Cisco Unified CCX Fault Tolerance

Although Cisco Unified CCX for Cisco Unified CME only supports a single server deployment, this solution offers some fault tolerance capabilities through other methods, as described in the following sections:

- [Cold Standby Server](#), page 3-5
- [Basic ACD](#), page 3-5

Cold Standby Server

The cold standby server deployment and configuration guidelines are the same as Cisco Unified CCX for Cisco Unified CM. See the “[Cisco Unified CCX Fault Tolerance](#)” section on page 2-27 for detailed information.

Basic ACD

Basic ACD (B-ACD) is an application running in Cisco Unified CME that provides auto-attendant and call distribution services for calls through the use of interactive menus and local hunt groups. It is a package of TCL scripts and audio prompts that can be downloaded from Cisco website for a specific Cisco Unified CME version. The menu options and the audio prompts for B-ACD can be customized for a specific need.

In the normal scenario, when there is an incoming call to a dial-peer in Cisco Unified CME, Cisco Unified CCX is notified and runs the configured application for the telephony trigger. However, assume that Cisco Unified CCX server is down for some reason so the inbound call to the dial-peer receives a busy tone. In this case, B-ACD can be used to temporarily handle the incoming call and route the call to the hunt group. If Cisco Unified CCX agent phones are put into the B-ACD hunt group, B-ACD can route the incoming calls to the Cisco Unified CCX agents (without CAD running).

To configure B-ACD to handle incoming calls when Cisco Unified CCX server is down, perform the following configurations in Cisco Unified CME:

1. Configure a low precedent voice dial-peer and set the destination-pattern and incoming called-number fields using the CME Telephony Trigger configured for the Cisco Unified CCX application. For example, if the Cisco Unified CCX application has the CME Telephony Trigger 8003 and its associated voice dial-peer in Cisco Unified CME has the preference of zero, the B-ACD voice dial-peer should be as follows:

```
!  
dial-peer voice 50001 voip  
  preference 5  
  service agentaa  
  destination-pattern 8003  
  session target ipv4:10.4.45.3  
  incoming called-number 8003  
  dtmf-relay h245-alphanumeric  
  codec g711ulaw  
  no vad  
!
```

2. Put the Cisco Unified CCX agent phones into the B-ACD hunt group.
3. Use the destination-pattern in the voice dial-peer as defined in Step 1 as the pilot number for B-ACD.

After finishing this configuration, when both Cisco Unified CME and Cisco Unified CCX are running, two voice dial-peers with the same destination-pattern but different preference will exist in Cisco Unified CME. Cisco Unified CCX will be notified when there is an incoming call to 8003 as illustrated in Figure 3-2 and the table that follows.

Figure 3-2 Two Voice Dial-Peers under Normal Operation

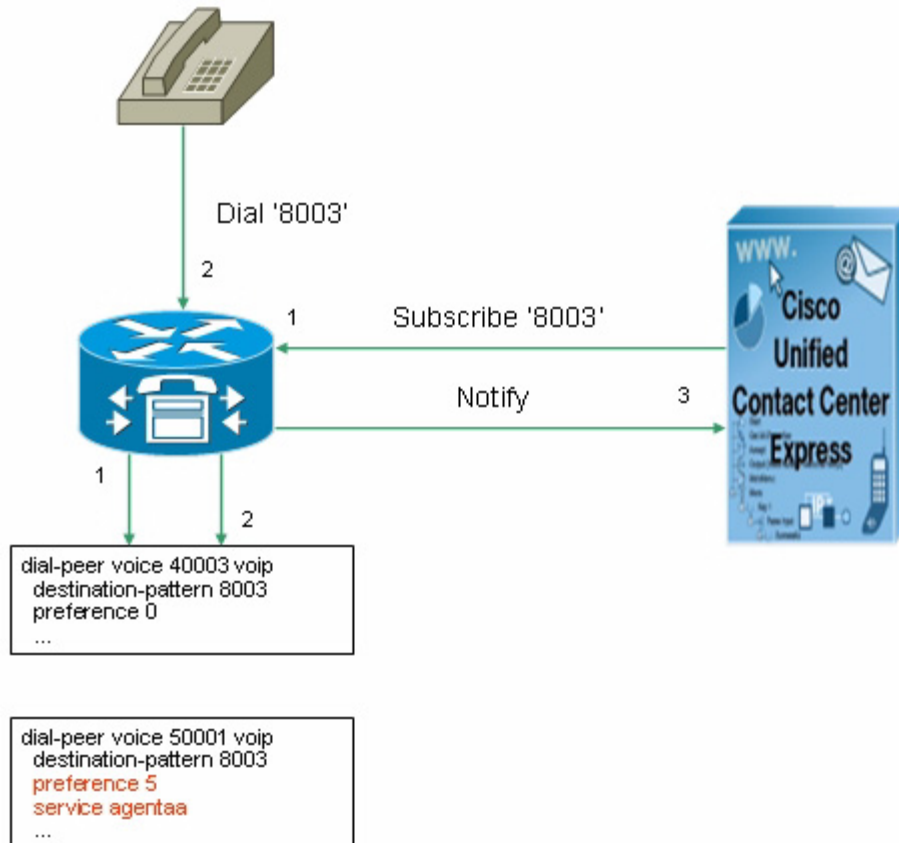

Step	Activity
1	Cisco Unified CCX starts up and finds the telephony trigger 8003, and it sends a subscription to Cisco Unified CME to receive all call related events on that trigger. Cisco Unified CME internally creates a voice dial-peer with destination-pattern 8003 and preference 0.
2	Incoming call to 8003 in Cisco Unified CME matches the voice dial-peer with destination-pattern 8003 and preference 0 because it has a higher precedence.
3	Cisco Unified CME notifies Cisco Unified CCX about the call arrival.

When Cisco Unified CCX server is down, the voice dial-peer with preference 0 disappears and leaves the voice dial-peer with preference 5 in Cisco Unified CME. If there is an incoming call to 8003, B-ACD is triggered as illustrated in Figure 3-3 and the table that follows.

Figure 3-3 One Voice Dial-Peer when Cisco Unified CCX is Down

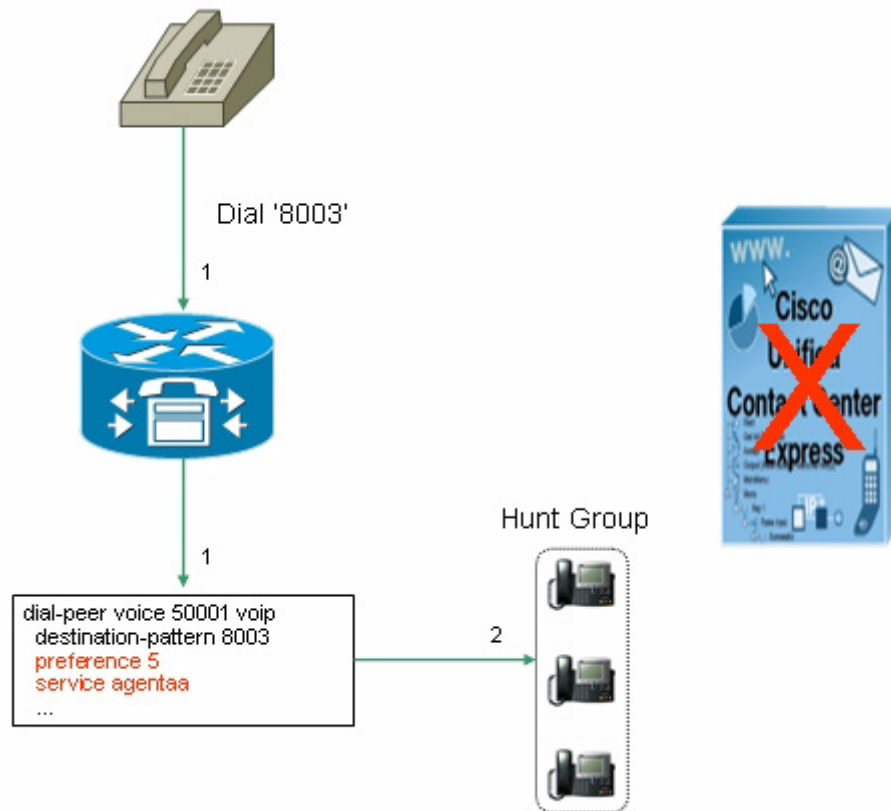

Step	Activity
1	Incoming call to dial-peer 8002 matches the dial-peer with destination-pattern 8003 in Cisco Unified CME, which is the B-ACD pilot number.
2	B-ACD runs, selects an agent from the hunt group and rings the phone.

When using B-ACD as backup for Cisco Unified CCX to handle call, be aware of the following:

- There will be no CDR or any kind of record for the incoming call written to Cisco Unified CCX database.
- Whenever B-ACD runs (regardless of whether Cisco Unified CCX is running), it shuts down the CallMonitor Module (CMM). You will have to manually re-enable CMM using CLI, otherwise Cisco Unified CCX will not be notified if there is any incoming call. For detail information about enabling CMM using CLI, please refer the *Cisco Unified Communications Manager Express System Administrator Guide*.

For detail information about B-ACD, refer the *Cisco Unified CME B-ACD and Tcl Call-Handling Applications*, which is available at this URL:

http://www.cisco.com/en/US/products/sw/voicesw/ps4625/products_configuration_guide_book09186a00805f22ca.html



CHAPTER 4

Cisco Unified Contact Center Express Deployment Models

This chapter discusses the deployment models that are available for this Cisco Unified CCX release. Use the Cisco Unified CCX Configuration and Ordering Tool to help you determine the number and types of servers required for any supported deployment model and call processing requirements (see [Chapter 6, “Sizing Cisco Unified Contact Center Express and Cisco Unified Communications Manager Servers”](#)). Before using that tool, it is a good idea to have a good understanding of what deployment model you desire.

Cisco Unified Communications Manager (Cisco Unified CM) coresident with Cisco Unified CCX deployment is not supported in Cisco Unified CCX 7.0 because Cisco Unified CM operates on a Linux server. Expansion servers where the Database, Monitoring, or Recording components are running on separate servers also are not supported.

[Table 4-1](#) depicts the deployment models that are supported in Cisco Unified CCX 7.0. These models have no bearing on which specific server model is used. The minimum server model required is identified by the Cisco Unified Contact Center Express Configuration and Ordering Tool. This chapter provides general rules for design and considerations and limitations for each of these deployment models. This information allows an Cisco Unified CCX system planner or designer to understand what other similar deployment models are supported and to understand how to determine the best solution for a given set of requirements.



Note

The Recording and Monitoring components are automatically installed on the Cisco Unified CCX server. However, activating these components is only necessary if recording and monitoring will be performed. When a Recording component is activated on a server, the Monitoring component must also be activated. When deploying with high availability and with recording and monitoring, the Recording and Monitoring components on both servers must be activated.

Table 4-1 Cisco Unified CCX 7.0 Deployment Models

Cisco Unified CCX Deployment Model	Cisco Unified CCX Components on Server 1	Cisco Unified CCX Components on Server 2
Single-Server Non-High Availability Deployment Model—Cisco Unified CM Integration	Engine, Database, Recording, Monitoring components	—
Two-Server High Availability Deployment Model—Cisco Unified CM Integration	Engine, Database, Recording, Monitoring components	Engine, Database, Recording, Monitoring components
Single-Server Non-High Availability Deployment Model—Cisco Unified CME Integration	Engine, Database, Recording, Monitoring components	—

Figure 4-1 depicts the deployment when integrating Cisco Unified CCX with Cisco Unified CM. In this deployment, optional Cisco Unified CCX components shown with an asterisk (*) can be added. These components are:

- Cisco Unified E-mail Interaction Manager and Cisco Unified Web Interaction Manager. For more details about deploying these components, refer the *Cisco Unified Web and E-Mail Interaction Manager Solution Reference Network Design (SRND) Guide for Cisco Unified Contact Center Express*, which is available at this URL:
http://www.cisco.com/en/US/products/ps7236/products_implementation_design_guides_list.html
- Cisco Unified Work Force Management and Cisco Unified Quality Manager.
- Cisco Unified Presence Server. For more details about deploying the Presence Server, refer the *Cisco Unified Communications SRND*, which is available at this URL:
<http://www.cisco.com/go/designzone>

For related information, see the “Cisco Unified CCX General Rules for Design” section on page 4-5.

Figure 4-1 Deployment Model of Cisco Unified CCX integrated with Cisco Unified CM

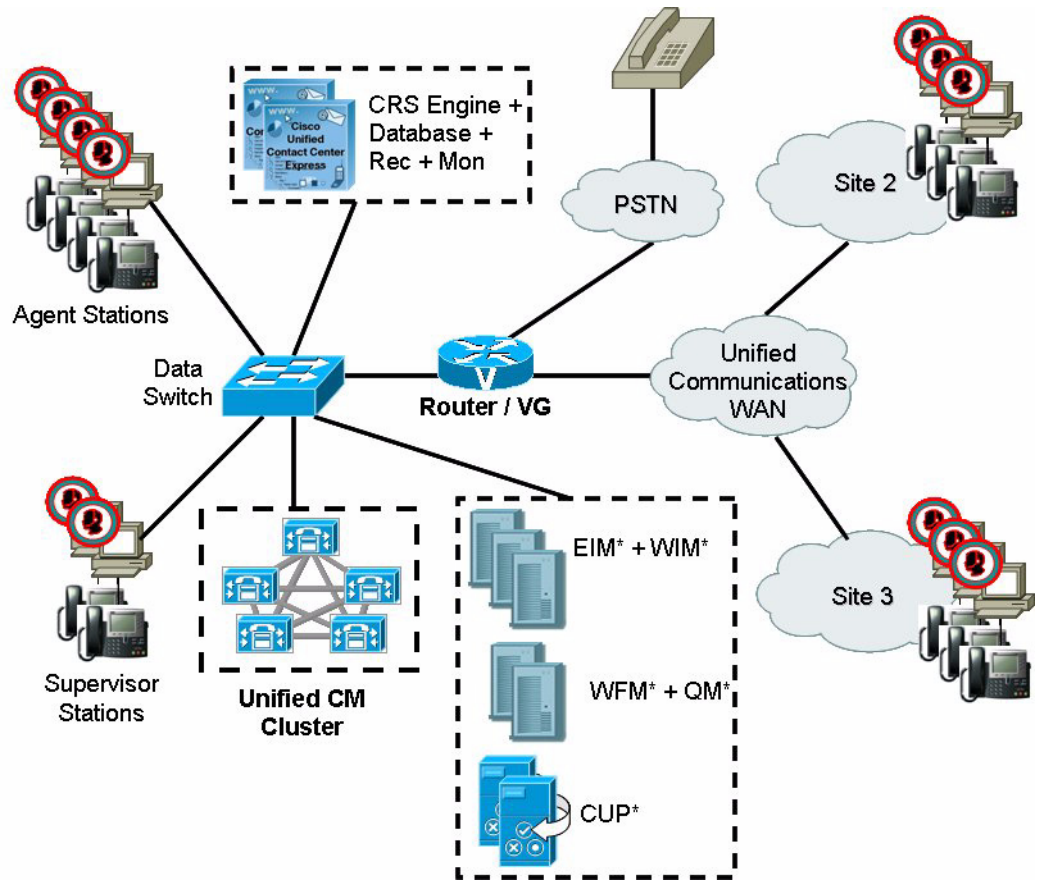
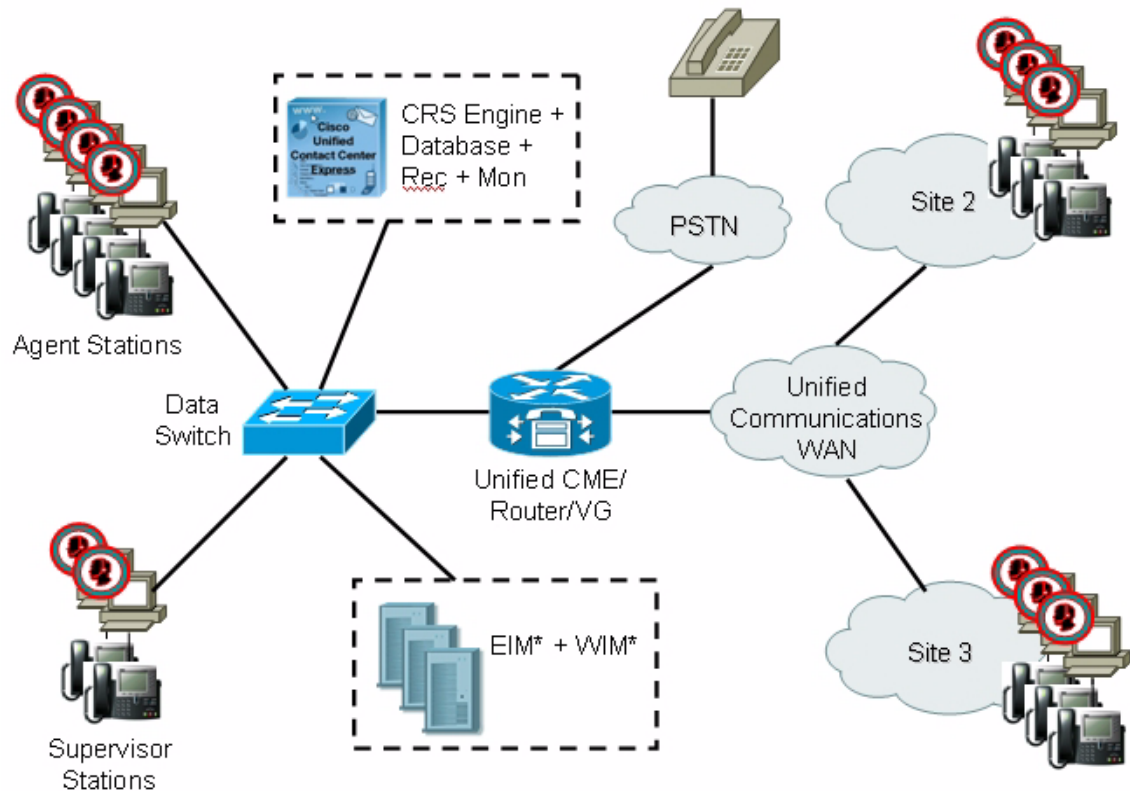

Figure 4-2 depicts the deployment when integrating Unified CCX with Cisco Unified Communications Manager Express (Cisco Unified CME).

Figure 4-2 Deployment Model of Cisco Unified CCX integrated with Cisco Unified CME



Note

In both deployment with Cisco Unified CM and with Cisco Unified CME, ASR and TTS can be added. ASR and TTS software is not provided by Cisco. This software must be purchased from a vendor such as a Nuance, Scansoft, or IBM. These vendors can provide design and server sizing requirements for their software.

This chapter contains the following sections:

- [Cisco Unified CCX General Rules for Design](#), page 4-5
- [Single-Server Non-High Availability Deployment Model—Cisco Unified Communications Manager Integration](#), page 4-6
- [Two-Server High Availability Deployment Model—Cisco Unified Communications Manager Integration](#), page 4-6
- [Single-Server Non-High Availability Deployment Model—Cisco Unified Communications Manager Express Integration](#), page 4-7
- [Other Design Considerations](#), page 4-8

Cisco Unified CCX General Rules for Design

When designing a Unified CCX deployment, the following rules apply:

- When deploying for high availability, the Cisco Unified CCX servers must be located in the same campus LAN and the round-trip delay between the Cisco Unified CCX servers should be less than 2 ms. The links between the Cisco Unified CCX servers must be highly available and the available bandwidth should always be considerably higher than the load, and there should be no steady-state congestion.

For additional information about LAN and campus infrastructure design, refer the *Cisco Unified Communications Solution Reference Network Design (SRND)* and to *Designing a Campus Network for High Availability SRND*, which are available at <http://www.cisco.com/go/designzone>.

**Note**

If the network connectivity is lost between the two Cisco Unified CCX engines, both Cisco Unified CCX engines become active (island mode). When the network connectivity is restored, both Cisco Unified CCX servers become inactive for a few seconds to negotiate the Cisco Unified CCX engine mastership, and all calls in queues and receiving call treatment are lost.

- The Cisco Unified CM servers running CTI Managers with which Cisco Unified CCX communicates must be located in the same campus LAN as the Cisco Unified CCX servers. The available bandwidth for these LAN links should always be considerably higher than the load, there should be no steady-state congestion, and the maximum round-trip delay between the servers should be less than 2 ms. Other Cisco Unified CM nodes within the same Cisco Unified CM cluster can be located across the WAN in a Cisco Unified CM cluster that is split over the WAN. In such deployments, the WAN requirements that are described in *Cisco Unified Communications SRND* must be satisfied.
- The Cisco Unified CME must be located in the same campus LAN as the Cisco Unified CCX server. The available bandwidth for these LAN links should always be considerably higher than the load, there should be no steady-state congestion, and the maximum round-trip delay between them should be less than 2 ms.
- If recording is going to be used for a high availability deployment, the Recording component must be redundant.
- All agents for a Cisco Unified CCX deployment must be using phones that register to the same Cisco Unified CM cluster. Calls can be received from devices and callers on another Cisco Unified CM cluster (using inter-cluster trunks).
- All Cisco Unified CCX deployments must be configured using the Cisco Unified CCX Configuration and Ordering Tool to be supported. Only the MCS 7835 and 7845 models provide redundant power supplies, redundant fans, and redundant hot-swappable disk drives. Therefore, use the MCS 7835 or the MCS 7845 for higher resiliency.
- For a high availability deployment:
 - Cisco Unified CCX standby node must use hardware platform that has the same capacity as the master node.
 - Cisco Unified CCX software and database versions must be the same in both the master and standby nodes.

When deploying Cisco Interaction Manager with Cisco Unified CCX, consider the following guidelines:

- Cisco Interaction Manager and Cisco Unified CCX servers must be separate.

- The Cisco Interaction Manager servers must be located in the same Campus LAN as the Cisco Unified CCX servers. The maximum round-trip delay between the Cisco Interaction Manager servers and the Cisco Unified CCX servers should be less than 5 ms.
- Cisco Interaction Manager can be deployed on a single server or on multiple servers for larger deployments. Refer the *Cisco Interaction Manager integration with Cisco Unified CCX SRND* for more details.

When deploying Quality Management and Workforce Management with Cisco Unified CCX, consider the following guidelines:

- Quality Management and Workforce Management must be installed on separate servers from each other and Cisco Unified CCX. No form of co-residency is supported in this release with any other software, such as installing on Cisco Unified CCX or installing both Quality Management and Workforce Management on the same server.
- WFO products do not provide redundancy. However, note that both Quality Management and Workforce Management do support redundant Cisco Unified CCX environment and are able to switch to a secondary or backup system upon failure of the primary Cisco Unified CCX system.
- Workforce Management and Quality Management servers should be installed on the same Campus LAN as the Cisco Unified CCX servers and the CTI Managers that they are communicating with. The round-trip delay between all these servers should be less than 2 ms

Single-Server Non-High Availability Deployment Model—Cisco Unified Communications Manager Integration

The Single-Server Non-High Availability Deployment Model—Cisco Unified CM integration is for small deployments. This deployment model places a single instance of all four Cisco Unified CCX software components on the same server. This deployment model may use either MSDE (default) or SQL Server as the database. The maximum database size with MSDE is 2 GB.

This deployment model can support silent monitoring and recording for agents at any WAN-connected site by using desktop monitoring. (Refer the *Cisco Unified CCX Software and Hardware Compatibility Guide* for a list of phones that support desktop monitoring). It can also support SPAN port monitoring for agents on the same VLAN segment as the Cisco Unified CCX server. This deployment model does not incorporate additional remote Monitoring components, so silent monitoring and recording is not possible for agents who are using the Cisco IP Phone Agent at remote sites. Similarly, silent monitoring and recording is not possible for agents at remote sites who are using phones that do not support desktop monitoring.

This deployment model allows the Cisco Unified CCX Engine to fail over to a backup CTI Manager if the primary CTI Manager fails. CTI ports and CTI route points should be grouped into device pools that have the same primary and secondary server list as those used for JTAPI communications with the CTI Managers.

Two-Server High Availability Deployment Model—Cisco Unified Communications Manager Integration

The Two-Server High Availability Deployment Model—Cisco Unified CM integration is for small to medium-sized contact centers requiring high availability. This deployment model incorporates redundant Cisco Unified CCX Engine, Database, Recording, and Monitoring components. The Cisco

Unified CCX servers and the Cisco Unified CM servers that are running CTI Managers with which Cisco Unified CCX communicates must be located in the same Campus LAN and the round-trip delay between these servers should be less than 2 ms.

SQL Server 2000 is required for high availability as SQL Server 2000 replication services are utilized to keep the databases synchronized.

This deployment model can support silent monitoring and recording for agents at any WAN-connected site by using desktop monitoring. (Refer the *Cisco Unified CCX Software and Hardware Compatibility Guide* for a list of phones that support desktop monitoring). It can also support SPAN port monitoring for agents on the same VLAN segment as the Cisco Unified CCX server. This deployment model provides redundancy for both recording and silent monitoring for all agents using desktop monitoring (regardless of location) or agents on the local VLAN using SPAN port monitoring. This deployment model does not incorporate additional remote Monitoring components, so silent monitoring and recording is not possible for agents who are using the Cisco IP Phone Agent at remote sites. Similarly, silent monitoring and recording is not possible for agents at remote sites who are using phones that do not support desktop monitoring.

This deployment model allows either Cisco Unified CCX Engine component to fail over to a backup CTI Manager if the primary server fails. CTI Ports and CTI Route Points should be grouped into device pools that have the same primary and secondary server list as that used for JTAPI communications to the CTI Managers.

**Note**

In HA deployments, historical data comes from the database located in the standby engine node. On newer platforms, a higher number of historical reporting sessions during operating hours is supported for HA deployments. Refer the Configuration and Ordering Tool for the limits.

Single-Server Non-High Availability Deployment Model—Cisco Unified Communications Manager Express Integration

As shown in [Figure 4-2 on page 4-4](#), Cisco Unified CCX integration with Cisco Unified CME supports only the Single-Server Non-High Availability Deployment Model—Cisco Unified CME integration. In this deployment model, the voice gateway and Cisco Unified CME can be located inside the same or separate router platform. Cisco Unified CME and the Cisco Unified CCX server must be located in the same campus LAN with the maximum round-trip delay less than 2 ms between them. This deployment model places a single instance of all four Cisco Unified CCX software components on the same server. This deployment model may use either MSDE (default) or SQL server as the database. The maximum database size with MSDE is 2 GB.

This deployment model can support silent monitoring and recording for agents at any WAN-connected site by using desktop monitoring. (Refer the *Cisco Unified CCX Software and Hardware Compatibility Guide* for a list of phones that support desktop monitoring). It can also support SPAN port monitoring for agents on the same VLAN segment as the Cisco Unified CCX server. This deployment model does not incorporate additional remote Monitoring components, so silent monitoring and recording is not possible for agents who are using the Cisco IP Phone Agent at remote sites. Similarly, silent monitoring and recording is not possible for agents at remote sites who are using phones that do not support desktop monitoring.

Cisco Unified CCX does not support backup Cisco Unified CME. If Cisco Unified CME fails, Cisco Unified CCX will not be functional.

**Note**

For deployment of Cisco Unified CCX integration with Cisco Unified CME:

- Incoming calls from PSTN trunk are supported
- SIP trunk calls from another Cisco Unified CME that is not integrated with Cisco Unified CCX are supported.

SIP and H.323 trunks are supported as usual in Cisco Unified CME but not when it is integrated with Cisco Unified CCX.

Other Design Considerations

Consider the following when designing your Cisco Unified CCX 7.0 system:

- High availability requires additional disk space, so historical call reporting capacity may be reduced. Historical call reporting capacity also depends upon BHCC, hours of operation per day, and days of operation per week. In some very high volume deployments with many agents, it may no longer be possible to retain a full 13 months of historical call reporting data. (This retention rate was assured in Cisco CRS 3.x releases)
- G.711 call recording requires about 1MB per minute. G.729 call recording requires about 256KB per minute.
- The following categories of data use hard disk space:
 - Windows Server OS, Cisco Unified CCX Software, and SQL Server Database Management Software
 - Cisco Unified CCX Logs
 - The Cisco Unified CCX Database (comprised of 4 data stores)
 - Recording Files.

Systems planners and designers should attempt to estimate the impact of each in order to determine hard disk requirements. The Cisco Customer Response Solutions Installation Guide provides more information about disk size requirements for very large installations.

- The Cisco Unified CM sizing tools assume devices are evenly distributed across all servers CTI Route Points be configured as part of a device pool that homes primarily to the same Cisco Unified Communications Manager Server as the primary CTI Manager being used, it may be required to run the Cisco Unified Communications Manager sizing tool on a per location or per server basis.
- The Cisco Unified CM QSIG path replacement feature is not supported for Unified CCX calls. For additional information about Unsupported Features in Cisco Unified CM, see the current release notes for Cisco Unified CCX.
- Cisco Unified CM Forced Authorization Codes and Client Matter Codes should be turned off for all route patterns in the Unified CM cluster that are used by Cisco Unified CCX. Enabling these features for route patterns that aren't used by Cisco Unified CCX does not affect Cisco Unified CCX.
- For a list of unsupported features in Cisco Unified CM with Cisco Unified CCX, refer to the current release notes for Cisco Unified CCX.
- Cisco Unified CCX supports different sets of IP Phones as agent device on Cisco Unified CM and Unified CME platforms; not all agent devices can be used as IP Phone Agent. For a complete list of supported agent devices, refer to the *Cisco Unified CCX Software & Hardware Compatibility Guide* available at:

http://www.cisco.com/en/US/products/sw/custcosw/ps1846/products_device_support_tables_list.html

- Sometimes new releases of Cisco Unified CM will not support Cisco Unified CCX immediately at Cisco Unified CM first customer ship (FCS) time. Some organizations may be early adopters of new Cisco Unified CM releases and may be slowed from migrating to new Cisco Unified CM releases and using new Cisco Unified CM features if Cisco Unified CCX is installed with that same Cisco Unified CM cluster. Therefore, in some scenarios, it may make sense to have a separate Cisco Unified CM cluster for Cisco Unified CCX.

Multiple Cisco Unified CCX Clusters Integrated with a Single Cisco Unified Communications Manager Cluster

It is possible to integrate multiple Cisco Unified CCX clusters with a single Cisco Unified Communications Manager cluster. Use the following guidelines when deploying this model:

- To determine if the number of Cisco Unified CCX clusters is appropriate for your Cisco Unified CM cluster, use the Cisco Unified CM capacity too. For more information, see [Chapter 6, “Sizing Cisco Unified Contact Center Express and Cisco Unified Communications Manager Servers.”](#)
- To determine if you need more than one CTI Manager, refer the *Cisco Unified Communications Solution Reference Network Design (SRND)*, available at <http://www.cisco.com/go/designzone>. For example, in Cisco Unified Communications Manager 5.1, up to 2,500 CTI devices are supported per CTI Manager.

If your deployment requires more than one CTI Manager, Cisco recommends that you load-balance Cisco Unified CCX and other CTI applications across the various CTI Managers in the cluster to provide maximum resilience, performance, and redundancy.

For additional CTI Manager best practices, refer the *Cisco Unified Communications Solution Reference Network Design (SRND)*, available at <http://www.cisco.com/go/designzone>.

- If more than one primary subscriber is required to support your configuration, distribute all agents equally among the subscriber nodes. This configuration assumes that the busy-hour call attempts (BHCA) is uniform across all agents.
- Each Cisco Unified CCX cluster is standalone and independent from other Cisco Unified CCX clusters. There is no communication or synchronization between the Cisco Unified CCX clusters. Agents should operate in only one Cisco Unified CCX cluster.

Cisco Unified CM Telephony Triggers (CTI Route Points) and CTI ports should be different across Cisco Unified CCX clusters.

- In the list of Resources in Cisco Unified CCX Administration, each Cisco Unified CCX cluster displays all the agents in the Cisco Unified Communications Manager cluster, even though the agents can operate and log in only to one Cisco Unified CCX cluster.

This situation requires that the Cisco Unified CCX Administrator be aware of which resources are associated with each cluster. The Cisco Unified CCX Administrator can mitigate this situation by having a unique naming convention for Resources associated with a particular Cisco Unified CCX cluster.

- This deployment is not intended to provide Cisco Unified CCX redundancy across different Cisco Unified CCX clusters. If a Cisco Unified CCX cluster fails, the agents that operate in this cluster cannot operate in other Cisco Unified CCX clusters. If another Cisco Unified CCX cluster is configured to accept the calls that were originally sent to the Cisco Unified CCX cluster that failed, there will be no report integration between the Cisco Unified CCX clusters.
- This deployment does not change the characteristics and design recommendations of each individual Cisco Unified CCX cluster. For example, within a Cisco Unified CCX cluster, high availability and cold standby are still supported.



CHAPTER 5

Basics of Call Center Sizing

This chapter introduces the basic concepts involved in call center sizing

This chapter contains the following sections:

- [Terminology, page 5-1](#)
- [Preliminary Information Requirements, page 5-2](#)
- [Principal Design Considerations for Call Center Sizing, page 5-4](#)
- [Planning Resource Requirements for Call Center Sizing, page 5-5.](#)

Terminology

Figure 5-1 illustrates the common port types and how they map to Cisco Unified CCX.

Figure 5-1 Call Center Port Types

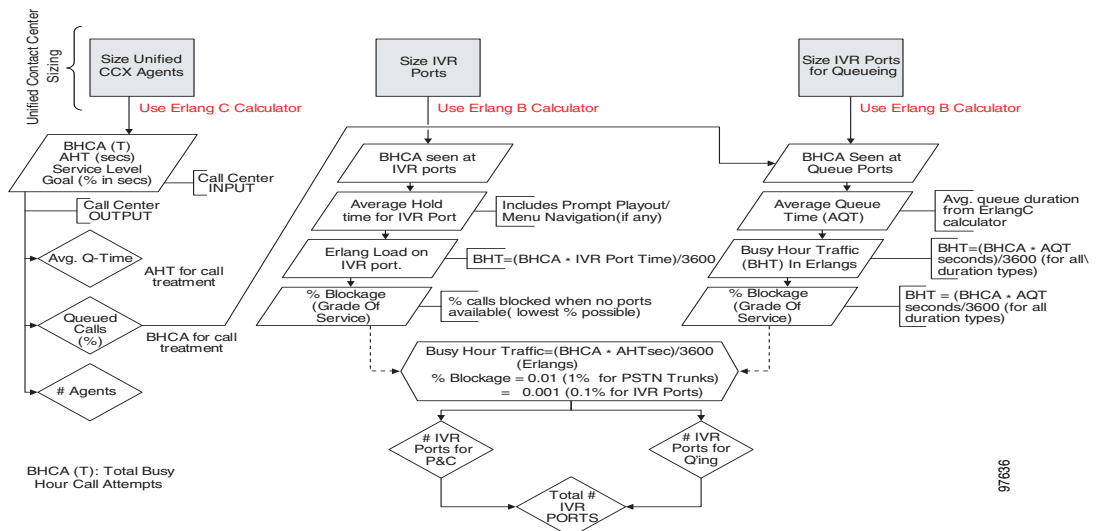

Call center sizing differentiates the port types as follows:

- **Gateway or PSTN trunk ports** — handle calls originating from the PSTN. They are purchased separately from Cisco Unified CCX.
- **Queue ports** — are IVR ports that queue calls (when no agents are available) prior to transferring the caller to an available agent. These ports are included at no additional cost with Cisco Unified CCX Standard or Enhanced, but they must be sized for proper capacity planning for the Cisco Unified CCX server. Refer the Cisco Unified CCX Configuration and Ordering Tool for more details.
- **IVR ports** — are full-featured IVR ports with all the capabilities found in the standalone Cisco Unified IP IVR product, except that the Cisco Unified CCX IVR ports require Cisco Unified CCX Premium and do not support Cisco Intelligent Contact Management Enterprise (Cisco Unified ICME) integration.

If you want additional supporting features, such as automatic speech recognition (ASR), text-to-speech (TTS), e-mail notification, web server or client functionality, and database operations, you simply need to purchase the Premium package. Additional seats may also be purchased for IVR port licenses if the number of port licenses that come with the seat licenses is not sufficient.

The goal of the system architect is to determine the appropriate number and types of IVR ports to provision for the Cisco Unified CCX system. However, as shown in [Figure 5-1](#), the Cisco Unified CCX architecture differs slightly from the example TDM call center configuration in that IVR ports and queue ports (and P&C ports as well) are combined into one logical CTI port. Therefore, the call sizing approach in this document calculates trunk, IVR, and queue ports. The remaining sections of this chapter use the term *IVR port* to denote the combined queue port and IVR port (both full-service and P&C ports).

Preliminary Information Requirements

System designers are advised to create a sizing document to do the following:

- Scope out the preliminary configuration information for the Cisco Unified CCX server.
- Size the gateways for the system.

To determine the size of the call center, obtain answers to the following questions:

- How many IVR ports do you need?
- How many PSTN gateway trunk ports do you need?
- How many agents will answer incoming calls?

To answer these questions properly, you will need the sizing metrics and information listed in [Table 5-1](#).

Table 5-1 Call Center Sizing Metrics

Metric	Description
Average handle time (AHT)	Average duration (talk time) of a call plus after-call work time, which is the wrap-up time after the caller hangs up.
Average IVR port usage time	The total time for prompt playout and/or menu navigation (if any) in the Cisco Unified CCX script. This should not include the queue time the caller spends waiting in queue before an agent becomes available. Queue time is calculated using Erlang-C automatically as shown in Figure 5-2 .

Table 5-1 Call Center Sizing Metrics (continued)

Metric	Description
Service level goal for agents	Percentage of calls answered by agents within a specific number of seconds.
Busy Hour Call Attempts (BHCA)	Average number of calls received in a busy hour.
Grade of service (% blockage) for gateway ports to the PSTN	Percentage of calls that get a busy tone (no gateway trunks available) out of the total BHCA.

All of the metrics in [Table 5-1](#) are basic call sizing metrics. Once this information is obtained, the number of gateway trunk ports, IVR ports, and agents can be calculated using the IPCC Resource Calculator available at: <http://tools.cisco.com/partner/ipccal/index.htm>

The IPC Resource Calculator uses Erlang C for sizing agents, and Erlang B for sizing IVR ports. The output of this sizing process will provide you with the total number of Gateway trunk ports, IVR ports and total number of agents to size the Cisco Unified CCX system properly.

See [Figure 5-2](#) for an overview of the IP call center sizing process, and see the section on [Planning Resource Requirements for Call Center Sizing, page 5-5](#), for detailed sizing information for both IVR ports and Cisco Unified CCX agents.

**Note**

If the system being designed is a replacement for an existing ACD or an expansion to an installed Cisco Unified CCX or Cisco Unified IP IVR system, you might be able to use the historical reporting information from the existing system to arrive at the above metrics.

In addition, call sizing design considerations may vary if the call center is more self-service oriented.

Principal Design Considerations for Call Center Sizing

Figure 5-2 illustrates the principal steps and design considerations for sizing a call center.

Figure 5-2 Cisco Unified CCX Design Process – Call Center Sizing

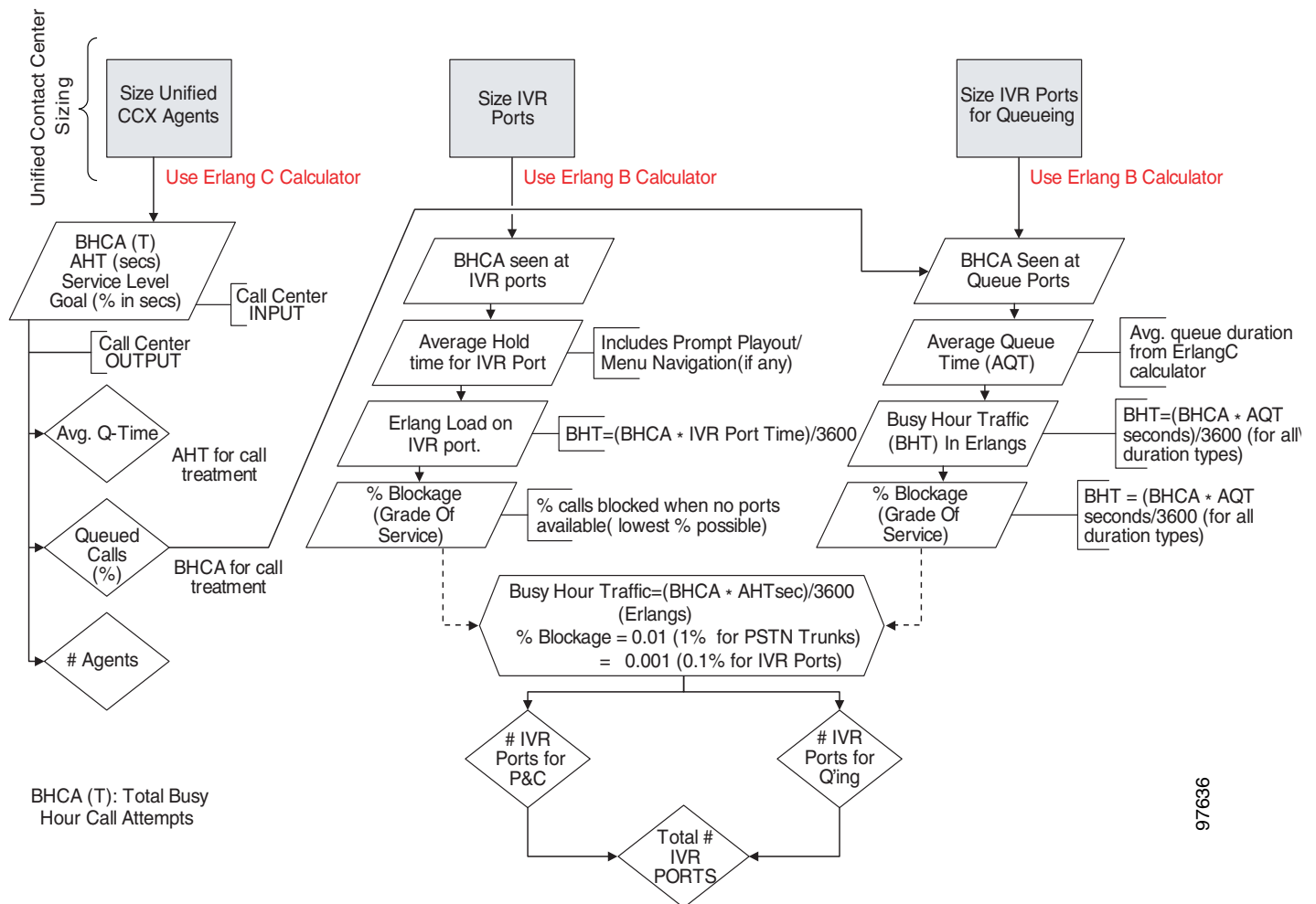

Figure 5-2 is a general overview of the design considerations for call sizing. For a detailed description of the call center sizing design process, refer the section on sizing call center resources in the *Cisco Unified Contact Center Enterprise Solution Reference Network Design Guide*, available online at the following URL:

<http://www.cisco.com/go/designzone>

There are similar basic call center sizing considerations and steps for Cisco Unified CCE, and they also can be used in sizing a smaller contact center for Cisco Unified CCX. This call sizing approach will provide you with the minimum number of IVR ports to support the total BHCA.

In addition, you should include the following design considerations, specific to Cisco Unified CCX, in your call center sizing calculations:

- At a minimum, plan on enough capacity to replace your existing system. The replacement system should perform at least as well as the one it is replacing.
- After all of the Erlang (C and B) calculations are complete for the call center sizing, any changes in queue times or agents will affect the total number of trunks and IVR ports required for an Cisco Unified CCX solution.
- As you increase the size of the agent pool, very small changes in the average queue time and percentage of queued calls will affect the required number of gateway trunks and IVR ports.
- Even if you perform all of the calculations for a call center, there are still some variables that you cannot plan for but that will affect the ports needed on a Cisco Unified CCX system. For example, one or more agents could call in sick, and that would affect the port count and queue time for each call. Just two agents calling in sick could increase the port count by over 12%. This would affect the price of the system and, if not planned for, would affect the ability of the call center to meet caller requirements. Properly sizing call center resources is integral to designing an effective Cisco Unified CCX system.

**Note**

Not all of the Cisco Unified CCX system limits are available at the same time.

If all of the call sizing information is available, the next step is to apply Cisco Unified CCX sizing limits to the call center requirements. For this step, use the Cisco Unified CCX Configuration and Ordering Tool, available online at:

http://www.cisco.com/en/US/partner/products/sw/custcosw/ps1846/prod_how_to_order.html

Planning Resource Requirements for Call Center Sizing

To assist you with planning resource requirements, this section illustrates how to size an Cisco Unified CCX Standard application with 25 agents.

Example of Sizing Cisco Unified CCX Standard Application with 25 Agents

This example is not intended to be a comprehensive contact center design example, but it illustrates how changing metrics such as BHCA, AHT, and Service Levels can affect provisioning of agents.

The following information applies to this example of Cisco Unified CCX Standard with 25 agents:

Metric	Metric Value
Busy Hour Call Attempts (BHCA)	800 calls in 60-minute interval
Service level goal	90% of all calls handled within 15 seconds
Average handle time (AHT)	90 seconds: <ul style="list-style-type: none"> • Average talk time = 90 seconds • Wrap-up time = 0 seconds
Wait before Abandon	120 seconds
Grade of service (% blockage) for gateway ports to the PSTN	1% (0.01)

Using the IPC Resource Calculator available at <http://tools.cisco.com/partner/ipccal/index.htm>, we can determine that 25 agents are needed for this system. Checking the Cisco Unified CCX Configuration and Ordering Tool indicates that all of these parameters fit within a single-server Cisco Unified CCX system.

Figure 4-3 provides a basic example of the IPC Standard Resource Calculator.

Figure 5-3 IPC Standard Resource Calculator Basic Example

Project Identification:	Basic Example	
Calls per interval (BHCA):	60 min	800 calls
Service Level Goal (SLG):	90 % within	15 sec 0m 15s
Avg call talk time:	90 sec	1m 30s
Avg after call work time:	0 sec	0m 0s
Avg handle time (Agent calls):	90 sec	1m 30s
Avg Call treatment Time (IVR):	0 sec	0m 0s
Wait before abandon (Tolerance):	120 sec	2m 0s
Blockage % (PSTN Trunks):	1 %	of calls lost (Busy)
Check to manually enter Agents	<input type="checkbox"/>	Agents
Recommended Agents: 25		
Calls completed (BHCC):	792 calls	8 Blocked calls
Calls answered within SLG:	92% within	15 sec
Calls answered beyond SLG:	8% beyond	15 sec
Queued calls:	19.3% 152 Q Calls	0.8 Erlangs
Calls answered immediately:	80.7% 639 calls	
Avg Queue Time(AQT):	17 sec	0m 17s
Avg Speed to Answer(ASA):	3 sec	0m 3s
Avg call duration:	93 sec	1m 33s
Agents utilization:	79%	
Calls exceeding Abandon Tolerance:	0%	0 Calls
PSTN Trunk Utilization:	66%	
Voice trunks required :	31 Trunks	T1/PRI 1.4 T1/PRI
IVR ports required for queuing:	5 IVR Ports	
IVR ports required for call treatment:	0 IVR Ports	
Sum of Required IVR Ports:	5	
<input type="button" value="Submit"/> <input type="button" value="Export"/>		

The IPC Resource Calculator also uses Erlang B and C to calculate the number of IVR ports needed for call treatment (prompt and collect) and queuing. An example of this is the default `icd.aef` script logic that is available with all the Cisco Unified CCX packages. Note in Figure 4-4 how the script logic allows the application developer to insert various delays in the script; these delays must be included in Average Call Treatment Time, (IVR) input to the IPC Resource Calculator.

Figure 5-4 Application Processing Time for Cisco Unified CCX

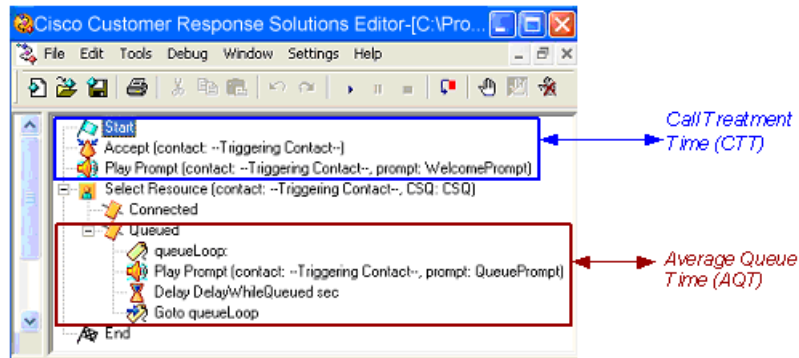

The following steps detail the procedure for calculating IVR ports for our example Cisco Unified CCX application:

-
- Step 1** Calculate the number of IVR ports required to handle IVR call treatment functionality:
- a. Estimate the average time the call is being processed by the Cisco Unified CCX script, from the time the initial call enters the application until the time the call is queued. This value is the call treatment time (CTT, also called Average IVR Delay). Using the default icd.aef script for our example, this value would be the time the welcome prompt is played. The welcome prompt used by this particular Cisco Unified CCX application was estimated at two seconds. (Note that a lengthy prompt/collect sequence for caller self-service will result in much longer CTT).
 - b. Now enter the CTT (Average IVR Delay) of 20 seconds into the IPC Resource Calculator, and notice that in this example ten IVR ports are required for call treatment.
- Step 2** Calculate the number of IVR Ports required to handle queuing functionality.
- In this case the IPC Resource Calculator has already performed the calculation from the previous inputs, yielding a value of six IVR ports required for queuing.
- Step 3** Calculate the total number of IVR Ports required.
- The IPC Resource Calculator automatically adds up all IVR ports required (queuing, call treatment and self service (using the advanced IPC Resource Calculator). In this example a total of fifteen IVR ports are required.
- Note at this point that the IPC Resource Calculator has also determined the number of Gateway Voice Trunks needed to support the required number of Agents and IVR ports. In this example, 36 PSTN trunks (DS0's) are required.

Figure 5-5 Standard Resource Calculator Call Treatment Example

Project Identification:	Call Treatment Example	
Calls per interval (BHCA):	60 min	800 calls
Service Level Goal (SLG):	90 % within	15 sec 0m 15s
Avg call talk time:	90 sec	1m 30s
Avg after call work time:	0 sec	0m 0s
Avg handle time (Agent calls):	90 sec	1m 30s
Avg Call treatment Time (IVR):	20 sec	0m 20s
Wait before abandon (Tolerance):	120 sec	2m 0s
Blockage % (PSTN Trunks):	1 %	of calls lost (Busy)
Check to manually enter Agents	<input type="checkbox"/>	Agents

Recommended Agents: 25	
Calls completed (BHCC):	792 calls 8 Blocked calls
Calls answered within SLG:	92% within 15 sec
Calls answered beyond SLG:	8% beyond 15 sec
Queued calls:	19.3% 152 Q Calls 0.8 Erlangs
Calls answered immediately:	80.7% 639 calls
Avg Queue Time (AQT):	17 sec 0m 17s
Avg Speed to Answer (ASA):	3 sec 0m 3s
Avg call duration:	113 sec 1m 53s
Agents utilization:	79%
Calls exceeding Abandon Tolerance:	0% 0 Calls
PSTN Trunk Utilization:	69%
Voice trunks required:	36 Trunks T1/PRI 1.7 T1/PRI
IVR ports required for queuing:	5 IVR Ports
IVR ports required for call treatment:	10 IVR Ports
Sum of Required IVR Ports:	15

Note that changes in BHCA, CCT, and service level will affect the overall number of ports and agents required in a call center. Each increase or decrease in call handling time will affect the number of ports much more dramatically than in a smaller call center.

For more gateway sizing guidance, refer the *Cisco IP Telephony Solution Reference Network Design* documentation available at <http://www.cisco.com/go/designzone>.



CHAPTER 6

Sizing Cisco Unified Contact Center Express and Cisco Unified Communications Manager Servers

This chapter helps you size the Cisco Unified CCX Server and the Cisco Unified Communications Manager (Cisco Unified CM) Server.

This chapter contains the following sections:

- [Cisco A2Q Bid Assurance Requirements, page 6-1](#)
- [Sizing Tools, page 6-1](#)
- [Affect of Performance Criteria on the Cisco Unified CCX Server, page 6-2](#)
- [Impact of Performance Criteria on the Cisco Unified CM Server\(s\), page 6-3](#)

Cisco A2Q Bid Assurance Requirements

The Assessment to Quality (A2Q) process is a Cisco design review and deployment assessment initiative that identifies and solves solution issues before a deal gets booked. Cisco Customer Contact Business Unit (CCBU) requires that all new Cisco Unified CCX deals be submitted to the A2Q Contact Center team.

Please note the following requirements:

- The Cisco A2Q process must be followed for every Cisco Unified CCX deployment.
- Every Cisco Unified CCX deployment must use the Cisco Unified CCX Configuration and Ordering Tool. The tool will either automatically bid assure a configuration or will flag that a manual bid assurance review is required.
- Every Cisco Unified CCX configuration must be bid assured prior to making a final offer to a customer.

Sizing Tools

The Cisco Unified CCX Configuration and Ordering Tool for Cisco Unified CCX and Cisco Unified IP IVR 7.0 must be used to size Cisco Unified CCX and Cisco Unified IP IVR systems. Also, the Cisco Unified CM Capacity Tool (CMCT) is the only approved tool and must be used to properly size the Cisco Unified CM server(s). Before sizing the servers, first familiarize yourself with the on-line Help and frequently asked questions (FAQs) of the tools before using them to size your systems.

**Note**

Cisco recommends that you count outbound agents as inbound agents when performing sizing in CMCT.

For deployments with more than 150 agent phones on MCS 7835 or MCS 7845, Cisco recommends that you deploy a minimum of two subscriber servers and a combined TFTP publisher. This agent phone limit is server platform dependent. [Table 6-1](#) shows the maximum number of agent and non-agent phones supported on different server platforms for a 2-server Cisco Unified CM cluster with the publisher as the backup subscriber.

Table 6-1 *Maximum Number of Agent and Non-Agent Phones Supported for a 2-server Cisco Unified CM cluster on Different Platforms*

Server Platform	Maximum Number of Agent Phones	Maximum Number of Non-Agent Phones	Maximum BHCA per Agent
MCS 7816	50	10	30
MCS 7825	100	20	30
MCS 7835 or MCS 7845	150	30	30

The Configuration and Ordering Tool for Cisco Unified CCX and Cisco Unified IP IVR 7.0 is available online at:

http://www.cisco.com/en/US/partner/products/sw/custcosw/ps1846/prod_how_to_order.html

Only the 7.0 version of the Cisco Unified CCX Configuration and Ordering Tool is valid for Cisco Unified CCX 7.0 configurations.

The tools are available online for partner access to account for the capacity required in Cisco Unified CM servers to handle CTI and call processing for Cisco Unified CCX.

- Cisco Unified Communications Sizing Tool is available online at: <http://tools.cisco.com/cuust>
- Cisco Unified CM Capacity Tool is available online at: <http://www.cisco.com/cgi-bin/CT/PGWCT/ct.cgi>

Affect of Performance Criteria on the Cisco Unified CCX Server

System performance criteria fall into two general categories:

- Cisco Unified CCX and Cisco Unified IP IVR components - Applications, SW versions, capabilities, server types, and options and quantities that your system requires.
- System usage - The average number of calls placed and received per hour, the average call length, the scripts being executed, grammar used for ASR, and so forth.

Effect of Performance Criteria

Each performance criterion can have an effect on the performance of the Cisco Unified CCX or Cisco Unified IP IVR system. In general, the more Cisco Unified CCX or Cisco Unified IP IVR components that you install and the heavier the system usage, the higher the demand on the server. However, the performance criteria can also interact in various non-linear ways to affect performance. The

Configuration and Ordering Tool for Cisco Unified CCX and Cisco Unified IP IVR 7.0 can help you see and evaluate the effects of performance criteria on the Cisco Unified CCX and Cisco Unified IP IVR server.

Impact of Performance Criteria on the Cisco Unified CM Server(s)

Similarly, Cisco Unified CM system performance is influenced by many criteria such as:

- Software release versions— Using the capacity tool, make sure to select the Cisco Unified CM software version with which Cisco Unified CCX will be working.
- The type and quantity of devices registered, such as:
 - CTI ports (IP IVR ports for queuing, call treatment and self service)
 - Gateway (GW) ports
 - Agent phones
 - Route points
- The load processed by these devices (calls per second)
- Application call flows
 - IVR self-service
 - Call treatment/Prompt and collect
 - Routing to agents, % transfers and conferences
- Special Cisco Unified CM configuration and services
 - Other non-Cisco Unified CCX devices—IP phones, GW ports, Unity ports, dial plan, and so forth.
 - Music on Hold (MOH)
 - Tracing levels—Cisco Unified CM CPU resource consumption varies depending on trace level enabled. Changing trace level from Default to Full on Cisco Unified CM can increase CPU consumption significantly under high loads. Changing tracing level from Default to No tracing can also decrease CPU consumption significantly at high loads (this is not a recommended configuration and would not be supported by Cisco TAC). CPU consumption due to default trace will vary based on load, Cisco Unified CM release, applications installed; call flow complexity, and so on.
- Server platform type



CHAPTER 7

Bandwidth, Security, and QoS Considerations

This chapter presents some design considerations for provisioning network bandwidth, providing security and access to corporate data stores, and ensuring Quality of Service (QoS) for Cisco Unified CCX applications.

This chapter contains the following sections:

- [Estimating Bandwidth Consumption, page 7-1](#)
- [Serviceability and Security, page 7-11](#)
- [QoS and Call Admission Control, page 7-13](#)
- [CAC and RSVP, page 7-14](#)

Estimating Bandwidth Consumption

Bandwidth plays a large role in deployments involving:

- The centralized call processing model (Cisco Unified CCX at the central site)
- Any call deployment model that uses call admission control or a gatekeeper

Remote Agent Traffic Profile

Cisco Unified CCX signaling represents only a very small portion of control traffic (Agent/Supervisor Desktop to and from the Cisco Unified CCX Server) in the network. For information on TCP ports and Differentiated Services Code Point (DSCP) marking for Cisco Unified CCX and CTI traffic, see the sections on [Serviceability and Security, page 7-11](#), and [QoS and Call Admission Control, page 7-13](#).

Bandwidth estimation becomes an issue when voice is included in the calculation. Because WAN links are usually the lowest-speed circuits in an IP Telephony network, particular attention must be given to reducing packet loss, delay, and jitter where voice traffic is sent across these links. G.729 is the preferred codec for use over the WAN because the G.729 method for sampling audio introduces the least latency (only 30 msec) in addition to any other delays caused by the network.

Where voice is included in bandwidth, system architects should consider the following factors:

- Total delay budget for latency (taking into account WAN latency, serialization delays for any local area network traversed, and any forwarding latency present in the network devices). The generally agreed-upon limit for total (one-way) latency for applications in a network is 150 milliseconds.

- Impact of delays inherent in the applications themselves. 8 seconds is the average Cisco Unified CCX agent login time with no WAN delay. This includes the exchange of approximately 1,000 messages between the agent application and various servers. The overall time to log in agents increases by approximately 30 seconds for each 30 milliseconds of WAN delay.
- Impact of routing protocols. For example, Enhanced Interior Gateway Routing Protocol (EIGRP) uses quick convergence times and conservative use of bandwidth. EIGRP convergence also has a negligible impact on call processing and Cisco Unified CCX agent logins.
- Method used for silently monitoring and recording agent calls. The method used dictates the bandwidth load on a given network link.

Silent Monitoring Bandwidth Usage

The silent monitoring feature of the CAD desktop software, which includes both listening to and recording agent calls, has the largest bandwidth requirements for the CAD product. Properly configuring this feature is especially important for remote agents who are connected to the main site by a WAN connection.

An agent's call can be listened to or recorded by the CAD software. To do this, a request is sent to a VoIP provider. The VoIP provider, captures the voice streams representing the call (two voice streams per call) and sends them back to the requestor. The bandwidth requirements detailed in this section are for the network links between the requestor and provider.

Silent Monitoring Requestors

There are two possible requestors in the CAD software:

- CSD
- Recording service

CSDs will send requests when the supervisor wishes to listen to an agent's call in real-time. The VoIP provider will capture the voice streams and send them back to the supervisor's desktop where they can be listened to over the desktop's speakers.

A Recording service will send requests when either a supervisor or agent wishes to record the call. The VoIP provider will send the voice streams and the Recording service will save the streams to disk so they can be listened to at a later time.

In Cisco Unified CCX 7.0, the Recording service is installed on the Cisco Unified CCX server.

Silent Monitoring Providers

There are also two possible VoIP providers in the CAD software:

- Cisco Agent Desktop
- VoIP Monitor service

The Cisco Agent Desktop application contains a service referred to as the Desktop Monitor service that runs on the agent's desktop. It is responsible for processing silent monitoring requests only for the agent logged into the CAD application on the desktop. It captures voice packets sent to the IP or soft phone associated with the logged in agent. The IP phone must be connected in series with the agent desktop on the network for this to work.

By default, this service is active on all agent desktops when the application is started. After initial installation of the CAD servers, all agents are already configured to use the Desktop Monitor service for the silent monitoring feature.

A VoIP Monitor service is able to handle multiple requests for silent monitoring simultaneously. It captures packets directly from the switch via the switch's Switched Port Analyzer (SPAN) configuration. In a deployment without high availability, Cisco Unified CCX 7.0 supports one VoIP Monitor service, which is installed on the Cisco Unified CCX server. When high availability is deployed, two VoIP Monitor services are installed, one on each Cisco Unified CCX server.

**Note**

IP Phone agents, who don't have a desktop, must be configured to use a VoIP Monitor service for the silent monitoring feature.

Figure 6-1 shows a representative Cisco Unified CCX installation supporting a remote office over a WAN. Both the main office and the remote office have a VoIP and Recording service on site.

Figure 7-1 Contact Center Representation

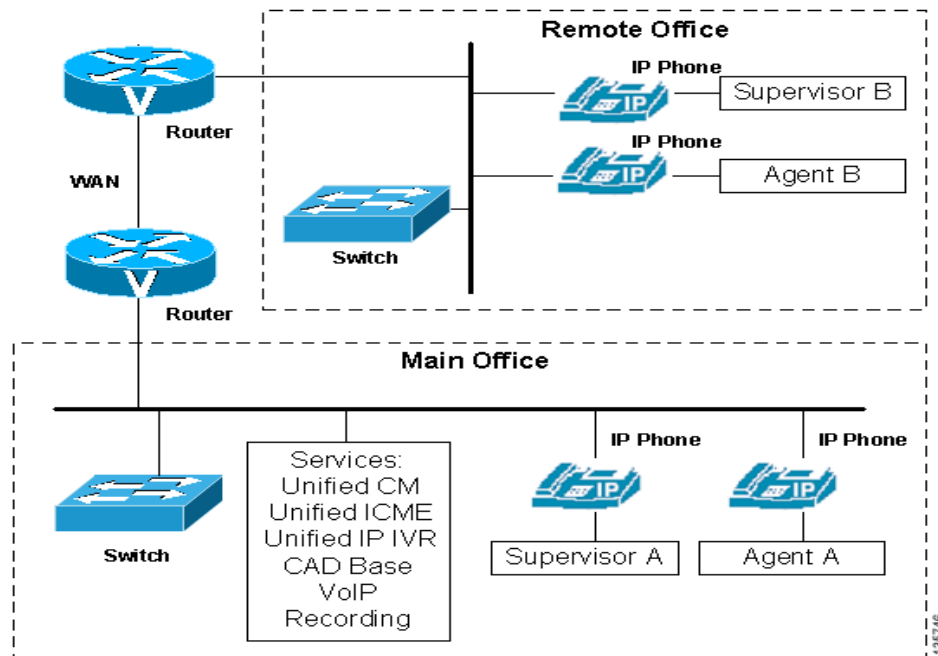

It is easy to see where the bandwidth will be required for the silent monitoring feature when you can locate the requestors and providers.

Regardless of who the requestor and VoIP provider are, the bandwidth requirement between these two points is the bandwidth of the IP call being monitored and/or recorded. You can think of each monitoring and/or recording session as being a new phone call (2 voice streams) for calculating bandwidth. Therefore, to calculate bandwidth to support the Silent Monitoring feature, you can use the same calculations used to provision the network to handle call traffic.

IP Call Bandwidth Usage

An IP phone call consists of two streams of data. One stream is sent from phone A to phone B. The other stream is sent from phone B to phone A. The voice data is encapsulated into packets that are sent over the network. The amount of data required to store a voice stream is dependent upon the CODEC used to encode the data. The CAD software can support both the G.711 and G.729 CODEC.

The voice data itself is transmitted over the network using the Real-Time Transport Protocol (RTP). The RTP protocol supports the idea of *silence suppression*. When silence suppression is used, no voice packets are sent over the network if there is not sound. Otherwise, even packets that contain silence are sent. This lowers the average required bandwidth for a call. Although CAD supports silence suppression, the lower bandwidth requirements for silence suppression should not be used when provisioning the network because the worst case scenario would be where there is not silence in the call, requiring the full call bandwidth as if silence suppression was not enabled.

When calculating bandwidth for an IP call, you must use the size of the RTP packet plus the additional overhead of the networking protocols used to transport the RTP data through the network.

For example, G.711 packets carrying 20 ms of speech data require 64 kbps (kilobytes per second) of network bandwidth per stream. These packets are encapsulated by four layers of networking protocols (RTP, UDP, IP, and Ethernet). Each of these protocols adds its own header information to the G.711 data. As a result, the G.711 data, once packed into an Ethernet frame, requires 87.2 kbps of bandwidth per data stream as it travels over the network. Since an IP phone call consists of two voice streams, in this example, a call would require 174.4 kbps.

The amount of voice data in a single packet also influences the size of the packet and bandwidth. The example above used packets containing 20 milliseconds of speech for its calculations, but this value can be changed in the Cisco Unified CM configuration for each supported CODEC. Configuring packets to contain more speech information reduces the number of packets sent over the network and reduces the bandwidth since there are fewer packets containing the additional networking headers, but the packet sizes increase. [Table 7-1](#) shows the bandwidth required for a phone call for the different combinations of CODEC and amount of speech per packet.

Table 7-1 Per-Call Packet Size Bandwidth Requirements

CODEC	Milliseconds of speech per packet	Bandwidth required (Kbps) for a call
G.711	10	220.8
G.711	20	174.4
G.711	30	159.0
G.729	10	108.8
G.729	20	62.4
G.729	30	47.0
G.729	40	39.2
G.729	50	34.6
G.729	60	31.4



Note

These calculations are based on G.711 using a sampling rate of 64 kbps speech encoding and the G.729 using 8kbps. This means one second of speech encoded into the G.711 CODEC requires 65,536 bits (or 8,192 bytes) to represent one second of sound.

For full-duplex connections, the bandwidth speed applies to both incoming and outgoing traffic. (For instance, for a 100-Mbps connection, there is 100 Mbps of upload bandwidth and 100 Mbps of download bandwidth.) Therefore, an IP phone call consumes the bandwidth equivalent of a single stream of data. In this scenario, a G.711 IP phone call with no silence suppression and containing 20 milliseconds of speech per packet requires 87.2 kbps (174.4 / 2) of the available bandwidth.

Table 7-2 and Table 7-3 display the percentage of total bandwidth available, based on the network connection, that is required for simultaneous monitoring sessions handled by a VoIP provider.

The following notes apply to the bandwidth requirements shown in Table 8-8 and Table 8-9:

- The bandwidth values are calculated based on the best speed of the indicated connections. A connection's true speed can differ from the maximum stated due to various factors.
- The bandwidth requirements are based on upload speed. Download speed affects only the incoming stream for the IP phone call.
- The values are based upon each voice packet containing 20 milliseconds of speech.
- The number of bytes in each packet include the entire Ethernet encapsulation.
- The data represents the CODECs without silence suppression. With silence suppression, the amount of bandwidth used may be lower.
- The data shown does not address the quality of the speech of the monitored call. If the bandwidth requirements approach the total bandwidth available and other applications must share access to the network, latency (packet delay) of the voice packets can affect the quality of the monitored speech. However, latency does not affect the quality of recorded speech.
- The data represents only the bandwidth required for monitoring and recording. It does not include the bandwidth requirements for other Cisco Agent Desktop modules as outlined in other sections of this document.

Table 7-2 Available Upload Bandwidth Percentage for Simultaneous Monitoring Sessions with G.711 CODEC

Number of Simultaneous Monitoring Sessions	Percentage of Available Bandwidth Required (No Silence Suppression)							
	100 Mbps	10 Mbps	1.544 Mbps	640 kbps	256 kbps	128 kbps	64 kbps	56 kbps
Call only	0.1	0.9	5.6	13.6	34.1	68.1	Not supported (NS) ¹	
1	0.3	2.6	16.8	40.9	NS	NS	NS	NS
2	0.4	4.4	28.1	68.1	NS	NS	NS	NS
3	0.6	6.1	39.3	95.4	NS	NS	NS	NS
4	0.8	7.8	50.5	NS	NS	NS	NS	NS
5	1.0	9.6	61.7	NS	NS	NS	NS	NS
6	1.1	11.3	72.9	NS	NS	NS	NS	NS
7	1.3	13.1	84.2	NS	NS	NS	NS	NS
8	1.5	14.8	95.4	NS	NS	NS	NS	NS
9	1.7	16.6	NS	NS	NS	NS	NS	NS
10	1.8	18.3	NS	NS	NS	NS	NS	NS

1. The bandwidth of the connection is not large enough to support the number of simultaneous monitoring sessions.

Table 7-3 Available Upload Bandwidth Percentage for Simultaneous Monitoring Sessions with G.711 CODEC

Number of Simultaneous Monitoring Sessions	Percentage of Available Bandwidth Required (No Silence Suppression)						
	100 Mbps	10 Mbps	1.544 Mbps	640 kbps	256 kbps	128 kbps	64 kbps
Call only	0.0	0.3	2.0	4.9	12.2	24.4	48.8
1	0.1	0.9	6.0	14.6	36.6	73.1	Not supported (NS) ¹
2	0.2	1.6	10.0	24.4	60.9	NS	NS
3	0.2	2.2	14.1	34.1	85.3	NS	NS
4	0.3	2.8	18.1	43.9	NS	NS	NS
5	0.3	3.4	22.1	53.6	NS	NS	NS
6	0.4	4.1	26.1	63.4	NS	NS	NS
7	0.5	4.7	30.1	73.1	NS	NS	NS
8	0.5	5.3	34.1	82.9	NS	NS	NS
9	0.6	5.9	38.1	92.6	NS	NS	NS
10	0.7	6.6	42.2	NS	NS	NS	NS

1. The bandwidth of the connection is not large enough to support the number of simultaneous monitoring sessions.

Bandwidth Requirements for VoIP Monitor Service

Although the bandwidth requirements are the same between the VoIP Monitor service and the Desktop Monitor service, the VoIP Monitor service can handle more simultaneous sessions (since it runs on the server). [Table 7-4](#) and [Table 7-6](#) expand upon the [Table 7-2](#) and [Table 7-3](#) by increasing the number of simultaneous sessions.

Table 7-4 Available Upload Bandwidth Percentage for Simultaneous Monitoring Sessions with G.711 CODEC

Number of Simultaneous Monitoring Sessions	Percentage of Available Bandwidth Required (No Silence Suppression)		
	100 Mbps	10 Mbps	1.544 Mbps
1	0.3	2.6	16.8
5	1.0	9.6	61.7
10	1.8	18.3	Not supported (NS) ¹
15	2.6	26.2	NS
20	3.5	34.9	NS
25	4.4	43.6	NS
30	5.2	52.3	NS
35	6.1	61.0	NS
40	7.0	69.8	NS

Table 7-4 Available Upload Bandwidth Percentage for Simultaneous Monitoring Sessions with G.711 CODEC

Number of Simultaneous Monitoring Sessions	Percentage of Available Bandwidth Required (No Silence Suppression)		
	100 Mbps	10 Mbps	1.544 Mbps
45	7.8	78.5	NS
50	8.7	87.2	NS

1. The bandwidth of the connection is not large enough to support the number of simultaneous monitoring sessions.

Table 7-5 Available Upload Bandwidth Percentage for Simultaneous Monitoring Sessions with G.711 CODEC

Number of Simultaneous Monitoring Sessions	Percentage of Available Bandwidth Required (No Silence Suppression)		
	100 Mbps	10 Mbps	1.544 Mbps
1	0.1	0.9	6.0
5	0.3	3.4	22.1
10	0.7	6.6	42.2
15	0.9	9.4	60.2
20	1.2	12.5	80.3
25	1.6	15.6	Not supported (NS) ¹
30	1.9	18.7	NS
35	2.2	21.8	NS
40	2.5	25.0	NS
45	2.8	28.1	NS
50	3.1	31.2	NS

1. The bandwidth of the connection is not large enough to support the number of simultaneous monitoring sessions.

CAD Desktop Applications Bandwidth Usage

The CAD desktop applications include the following:

- Cisco Agent Desktop
- Cisco Supervisor Desktop
- Cisco Desktop Administrator

These applications also require a certain amount of bandwidth, although far less than the Desktop Monitor service. In addition, the type of communication across the network is bursty. In general, bandwidth usage is low when the agents are not performing any actions. When features or actions are requested, the bandwidth increases for the time it takes to perform the action, which is usually less than one second, then drop down to the steady state level. From a provisioning standpoint, one must determine the probability of all the CAD agents performing a particular action at the same time. It might be more helpful to characterize the call center and determine the maximum number of simultaneous actions (in the worst case) to determine instantaneous bandwidth requirements, then determine what amount of delay is tolerable for a percentage of the requested actions.

For example, the raw bandwidth requirement for 300 CAD agents logging in simultaneously is about 4.5 Kilobytes/second and the login time is about 9 seconds (with no network delay) for each agent. If the WAN link did not have this much bandwidth, logins would take longer as packets were queued before being sent and received. If this caused the login attempts to take twice as long (18 seconds), would this delay be acceptable? If not, more bandwidth should be provisioned.

Each of these applications communicates with the base CAD services running on server machines. In addition, the agent desktop application communicates with the CTI server for call control actions and state changes. [Table 7-6](#) displays the types of messaging for each application.

Table 7-6 **Messaging Type By CAD Desktop Application**

Application Name	Message types
Cisco Agent Desktop	Login/Logoff Agent state changes Call control Call status Information Desktop Monitoring/Recording Chat messages Team Performance messages Report generation Real-time data refresh
Cisco Supervisor Desktop	Login/Logoff Agent state updates Call status updates Report generation Silent Monitoring Call Recording Call Playback Chat messages Team Performance messages Real-time data refresh
Cisco Desktop Administrator	Configuration information retrieval and storage Configuration data refresh

Cisco Agent Desktop Bandwidth Usage

CAD agents are able to login and logoff their agents, change their agent state, handle calls, and send reporting information to the base servers. The bandwidth requirements for these activities are fairly small but can add up when many agents are considered.

[Table 7-10](#) displays the average bandwidth requirements for different numbers of agents. This information is derived from bandwidth testing and extrapolation of bandwidth data. Since there are many variables that can affect bandwidth, a configuration that resulted in higher bandwidth usage was chosen to provide near worst-case scenarios. If the agent's WAN link meets or exceeds the bandwidth requirements shown in this table, Cisco Agent Desktop will be able to run without delays in message passing.

The configuration parameters that affect bandwidth and apply to tables 8-13 and 8-14 are shown below.

- Number of skills per agent: 10
- Number of agents per team: 20

- Number of teams: 50
- Number of agent state changes per agent per hour: 10 (does not count state changes due to handling calls)
- Calls per agent per hour: 60
- Team Performance Messages per team per hour: 8
- Chat messages sent/received per hour: 20
- Average chat message size (in bytes): 40
- Number of calls recorded per hour: 0

**Note**

The bandwidth requirements shown do not include the bandwidth of the RTP streams for the call, recording, or monitoring session.

Table 7-7 Average Bandwidth Requirements For Cisco Agent Desktop

Number of agents	Average Download Bandwidth (Kilobytes/second)	Average Upload Bandwidth (Kilobytes/second)
1	0.03	0.05
10	0.2	0.3
50	1.1	1.5
100	2.2	3.0
150	3.3	4.5
200	4.4	6.0
250	5.5	7.0
300	6.6	9.0

Cisco Agent Desktop provides a bandwidth calculator that can be used with both Cisco Unified CCX and Cisco Unified CCE. Additional information about the Cisco Agent Desktop Bandwidth Calculator is available at <http://www.cisco.com/univercd/cc/td/doc/product/icm/bandcalc/index.htm>.

Cisco Supervisor Desktop Bandwidth Usage

A CSD will receive events for all the agent's of the team that the supervisor is logged into. This information includes state changes, call handling, login/logoff, and so on. The more agents, skills, and calls there are, the more data will be sent to supervisors. In addition, particular reports are automatically refreshed periodically to provide real-time data while the supervisor is viewing the report. Refreshing reports requires additional bandwidth.

Table 7-8 uses the same basic configuration parameters used to determine the bandwidth numbers in Table 7-7, with the following differences:

- The calculations are based on 1 supervisor per 10 agents
- The Team Agent Statistics Report is viewed
- The Team Skill Statistics Report is viewed

Table 7-8 Bandwidth Requirements For Cisco Supervisor Desktop

Number of agents	Average Download Bandwidth (Kilobytes/second)	Average Upload Bandwidth (Kilobytes/second)
1	0.05	0.05
10	0.05	0.05
50	0.2	0.2
100	0.5	0.5
150	0.7	0.7
200	1.0	1.0
250	1.2	1.2
300	1.4	1.5

Cisco Desktop Administrator Bandwidth Usage

The bandwidth requirements for CDA are very small and are only seen when an administrator is actively changing configurations. In general, the bandwidth used by CDA is negligible from a provisioning standpoint.

Remote Agent Traffic Profile

Cisco Unified CCX signaling represents only a very small portion of control traffic (Cisco Unified CM CTI and ICD subsystems) in the network. For information on TCP ports and Differentiated Services Code Point (DSCP) marking for Cisco Unified CCX ICD and CTI traffic, see the sections on [Serviceability and Security, page 7-11](#), and [QoS and Call Admission Control, page 7-13](#).

Bandwidth estimation becomes an issue when voice is included in the calculation. Because WAN links are usually the lowest-speed circuits in an IP Telephony network, particular attention must be given to reducing packet loss, delay, and jitter where voice traffic is sent across these links. G.729 is the preferred codec for use over the WAN because the G.729 method for sampling audio introduces the least latency (only 30 milliseconds) in addition to any other delays caused by the network.

Where voice is included in bandwidth, system architects should consider the following factors:

- Total delay budget for latency (taking into account WAN latency, serialization delays for any local area network traversed, and any forwarding latency present in the network devices). The generally agreed-upon limit for total (one-way) latency for applications in a network is 150 milliseconds.
- Impact of delays inherent in the applications themselves. 25 seconds is the initial Cisco Unified CCX agent login setup time with no WAN delay. The overall time to log in agents and base delay adds approximately 30 seconds of delay per 30 milliseconds of WAN delay.
- Impact of routing protocols. For example, Enhanced Interior Gateway Routing Protocol (EIGRP) uses quick convergence times and conservative use of bandwidth. EIGRP convergence also has a negligible impact on call processing and Cisco Unified CCX agent logins.

Use Table 6-9 to estimate the number of Cisco Unified CCX agents that can be maintained across the WAN (with IP Telephony QoS enabled). These numbers are derived from testing where an entire call session to Cisco Unified CCX agents, including G.729 RTP streams, is sent across the WAN. Approximately 30% of bandwidth is provisioned for voice. Voice drops are more of an issue when you

are running RTP in conjunction with Cisco Agent Desktop and other background traffic across the WAN. These voice drops might occur with a specific number of agents at a certain link speed, and those possible scenarios are denoted by the entry N/A (not applicable) in Table 6-9.

Table 7-9 Remote Agents Supported by Cisco Unified CCX Across a WAN Link

Frame Relay	128 KB	256 KB	512 KB	768 KB	T1
G.729	3	7	15	25	38
G. 711	N/A	N/A	N/A	N/A	14

In remote agent deployments, QoS mechanisms should be used to optimize WAN bandwidth utilization. Advanced queuing and scheduling techniques should be used in distribution and core areas as well. For information on QoS traffic classification, see [QoS and Call Admission Control, page 7-13](#). For provisioning guidelines for centralized call processing deployments, refer the *Cisco IP Telephony Solution Reference Network Design* documentation, available online at: <http://www.cisco.com/go/designzone>.

Serviceability and Security

Security can be implemented on many levels. Applications security is clearly dependent upon security implemented at the infrastructure level. For more details on security at the network infrastructure level, refer the security design considerations in the *Cisco IP Telephony Solution Reference Network Design* documentation, available online at

<http://www.cisco.com/warp/public/779/largeent/it/ese/srnd.html>

Corporate Data Access

Aside from call routing, Cisco Unified CCX or Cisco Unified IP IVR scripts often process enterprise data from existing corporate data stores such as a database or a corporate directory server for functions such as account authorization and order status. Often, these data stores already exist and share data with other enterprise applications. [Figure 7-2](#) shows an example of a network where voice and data components reside in separate VLANs and are separated by a firewall.

Figure 7-2 Cisco Unified CCX Accessing Data Stores

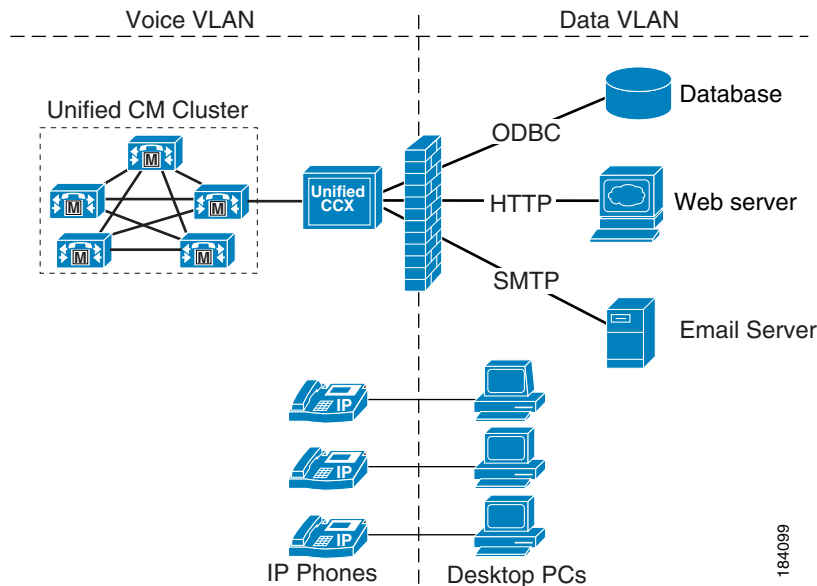

Cisco Unified CCX can communicate with these external sources through its subsystems, provided Network Address Translation (NAT) is not used.

Port Utilization for Product Revisions

For a list of the TCP and UCP ports used by Cisco Unified CCX 7.0, including Cisco Unified IP IVR and Cisco Unified CCX, see the Port Utilization Guide, which is accessible from the following web page: http://www.cisco.com/en/US/products/sw/custcosw/ps1846/products_installation_and_configuration_guides_list.html

Ping, NAT, PAT, and Reverse DNS Lookups

The following configurations and information are required for the CAD software to work properly.

The Cisco Agent Desktop application uses the TCP Ping command to verify that it can communicate with the active VoIP servers. This is done even if no agents are configured to use a VoIP Monitor service for the silent monitoring feature. If Ping is disabled on the machine running a CAD VoIP Monitor Server, the silent monitoring feature will not work properly.

There are certain CAD modules that rely upon reverse DNS lookups. If this feature is turned off on the machines running CAD services, there will be a loss of some functionality and errors will be generated and logged.

Network Address Translation (NAT) and Port Address Translation (PAT) are supported between CAD and the Cisco Unified CCX servers as long as the CAD client applications are behind a VPN. NAT is supported with IP Phone Agent (IPPA). However, it is required that you use static IP addresses for the IP Phone Agent phones as well as Static NAT. Dynamic NAT and address overloading are not supported. PAT is not supported with IPPA. Refer to the *Cisco CAD Installation Guide* for more detail.

QoS and Call Admission Control

Quality of Service (QoS) becomes an issue when more voice and application-related traffic is added to an already growing amount of data traffic on your network. Accordingly, Cisco Unified CCX and time-sensitive traffic such as voice need higher QoS guarantees than less time-sensitive traffic such as file transfers or emails (particularly if you are using a converged network).

QoS should be used to assign different qualities to data streams to preserve Cisco Unified CCX mission-critical and voice traffic. The following are some examples of available QoS mechanisms:

- Packet classification and usage policies applied at the edge of the network, such as Policy Based Routing (PBR) and Committed Access Rate (CAR).
- End-to-end queuing mechanisms, such as Low Latency Queuing (LLQ). Because voice is susceptible to increased latency and jitter on low-speed links, Link Fragmentation and Interleaving (LFI) can also be used to reduce delay and jitter by subdividing large datagrams and interleaving low-delay traffic with the resulting smaller packets.
- Scheduling mechanisms such as Traffic Shaping to optimize bandwidth utilization on output links.

Classifying Cisco Unified CCX and Application-Related Traffic

Table 7-10 and the following section list TCP ports and DSCP markings for use in prioritizing Cisco Unified CCX and Cisco Unified CM mission-critical CTI traffic. The DSCP markings are not set by the software and have to be configured in the routers and switches. The performance criteria used in classifying such traffic should include:

- No packet drops on the outbound or inbound interface of the WAN edge router
- Voice (G.729) loss under 1%
- One-way voice delay under 150 msec

A detailed description of QoS is not within the scope of this design guide. For QoS design recommendations, refer the Quality of Service design guide available online at

<http://www.cisco.com/go/designzone>

Table 7-10 QoS Classifications for Cisco Unified CCX Interfaces

Cisco Unified CCX Component	Interface / Protocol	Port	DSCP Marking
CTI messaging between Cisco Unified CCX Cisco Unified CM Telephony subsystem and Cisco Unified CM (both directions)	CTIQBE	TCP 2748	CS3
HTTP (Cisco Unified CCX administration page and IPPA interface)	HTTP	TCP 6293	AF21
AXL to Cisco Unified CM for User configuration and authentication (SSL)	SOAP AXL	TCP 8433	AF21
E-mail	SMTP	TCP 25	CS0
Messaging data between Cisco Unified CCX and Cisco Agent Desktop	CTI	TCP 42027	CS3
	IMAP ¹	TCP 143	CS0

1. This is for Cisco Unified CCX Agent E-mail feature and does not apply to Cisco Agent Desktop Browser edition and IP Phone Agent

QoS Considerations for CAD software

The most important network traffic for quality of service consideration in the CAD software is the voice streams sent between VoIP requestors and providers. The processes that send and receive these voice streams have been set to have higher priorities than other processing threads. This helps assure that there will be no delays in processing these voice streams. However, The voice streams themselves contain no QoS markings. These markings are stripped off when the voice streams are captured by the VoIP provider's software. The networking components used to send these data streams (switches, routers, gateways) should be configured with the appropriate QoS settings to ensure the delivery of these voice streams to meet the intended QoS requirements.

CAC and RSVP

Cisco Unified CM supports Resource-Reservation Protocol (RSVP) between endpoints within a cluster. RSVP is a protocol used for Call Admission Control (CAC) and is used by the routers in the network to reserve bandwidth for calls. The bandwidth being controlled is only for the voice streams, call signalling traffic is not part of CAC.

Before RSVP, each Cisco Unified CM cluster maintained its own calculation of how many active calls were traversing between locations in order to calculate bandwidth usage. If more than one Cisco Unified CM cluster shared the same link, bandwidth would have to be carved out and dedicated for each cluster, and this led to inefficient use of available bandwidth. RSVP also enables customers to deploy complex network topology while Location-based CAC is limited to a hub-and-spoke type of topology.

RSVP solves this problem by tracing the path between two RSVP Agents that reside on the same LAN as the IP Phones. A software MTP or transcoder resource that runs on Cisco IOS routers can be RSVP Agents. The RSVP Agents are controlled by Cisco Unified CM and are inserted into the media stream between the two IP phones when a call is made. The RSVP Agent of the originating IP Phone will traverse the network to the destination IP Phone's RSVP Agent, and reserve bandwidth. Since the network routers (and not Cisco Unified CM) are keeping track of bandwidth usage, multiple phone calls can traverse the same RSVP controlled link even if the calls are controlled by multiple Cisco Unified CMs.

For more information, see the RSVP chapter in *Cisco Unified Communications Solution Reference Network Design (SRND)*.

Cisco Unified CCX selects a call center agent independent of the mechanism, using either RSVP or Location-based CAC; that is, Cisco Unified CCX routes a call to an available agent even though the agent phone might not be able to receive the call due to lack of bandwidth. Thus, proper sizing of bandwidth between sites is very important.

For any call transfer, there are moments when two calls are active. If any of the active calls traverses between sites, then CAC is used. Even when the original call is placed on hold during a transfer, that call still takes up the same amount of bandwidth just like an active call.

In [Figure 7-3](#) and [Figure 7-4](#), the voice gateway and agents are at a remote site, while the Cisco Unified CCX server is at a data center site. A call from PSTN reaches the voice gateway at the remote site and connects to Cisco Unified CCX at the data center. This takes one call bandwidth over the WAN link, which is represented by the caller stream. Once an agent is available and selected at the remote site, Cisco Unified CCX transfers the call to the agent.

Figure 7-3 Call from PSTN to Cisco Unified CCX Server to Agent

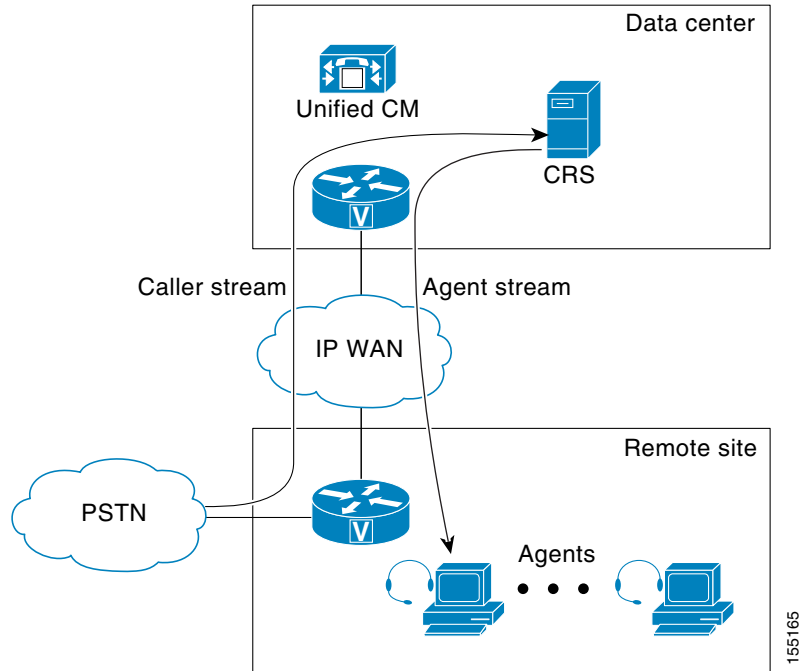

During the transfer, before the agent picks up the call, there is another call setup between Cisco Unified CCX and the agent phone. It takes up another call bandwidth over the WAN, and is represented by the agent stream in Figure 7-3. Once the agent picks up the call, the voice traffic is between the voice gateway and the agent phone, which are both at the remote site. At that time, no bandwidth is reserved over the WAN; see Figure 7-4. This example shows how call bandwidth is reserved in a contact center call that is eventually routed to an agent. Depending on where the voice gateway, the agents, and the Cisco Unified CCX server are located, proper WAN bandwidth should be provisioned.

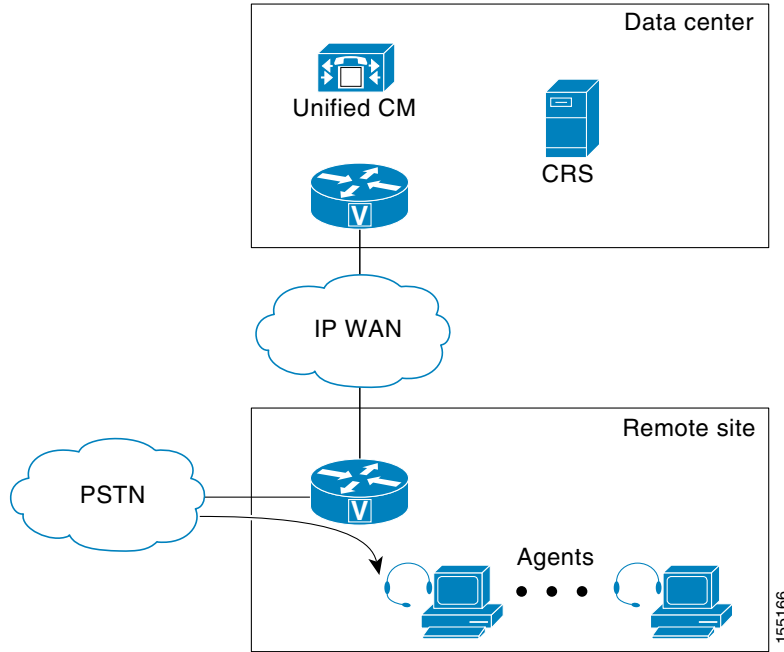
Figure 7-4 After Agent Picks Up Call



APPENDIX **A**

Server Capacities and Limits

Table A-1 provides a list of capacity limits when deploying Cisco Unified CCX.

Table A-1 Capacity Limits

	MCS-7845, Cisco Unified CM Deployment	All Supported Servers, Cisco Unified CME Deployment on ISR	All Supported Servers, Cisco Unified CME Deployment on UC500
Maximum number of inbound agents	300	50	48
Maximum number of outbound agents	300	Not supported	Not supported
Maximum number of supervisors	32	10	5
Maximum number of IVR ports	300	50	48

This table shows absolute limits. Reaching the limits for multiple criteria in a specific configuration might not be possible. Use the Configuration and Ordering tool to see the actual limits for your configuration and to validate your configuration. This tool is available at:

http://www.cisco.com/en/US/partner/products/sw/custcosw/ps1846/prod_how_to_order.html

The Configuration and Ordering tool also contains tables with more detailed server capacities and limits. Use the numbers in this tool as the final authority on capacities and limits.

The Configuration and Ordering Tool is available to Cisco partners only. If you are not a Cisco partner, you can find some capacity limits in *Getting Started with Cisco Unified Contact Center Express*. For more details and to validate your configuration, contact your Cisco sales engineer or Cisco partner to access this tool.

For Cisco Unified CCX Agent E-Mail capacity and limit, refer to the Configuration and Ordering Tool.

For information on capacity and sizing of Cisco Workforce Optimization, refer to *Cisco Workforce Optimization System Configuration Guide*.

For information on capacity and sizing of Cisco Unified Web and E-Mail Interaction Managers, refer to *Cisco Unified Web and E-Mail Interaction Manager Solution Reference Network Design (SRND) Guide for Unified Contact Center Express*.



APPENDIX **B**

Voice Over IP Monitoring

Monitoring and recording of agent calls can be supported by two different methods in this release of Cisco Unified CCX:

- Via the traditional VoIP monitor Service: captures packets directly from an IP network switch via the switch's Switched Port Analyzer (SPAN) configuration. Design considerations for the traditional SPAN-based VoIP monitor Service are provided at the end of this appendix (see [Design Considerations for SPAN-Based Services, page B-1](#)).
- Via the Cisco Agent Desktop, also known as Endpoint monitoring or the Desktop Monitoring Service: The agent's IP phone repeats RTP packets to the agent's PC. When a supervisor wants to monitor/record the agent, the supervisor application sends a message to the agent desktop to forward the RTP packets to the supervisor, who can then monitor the agent/caller conversation via the sound card on his or her PC. This method requires the agent to use the Cisco Agent Desktop (not the IP Phone Agent) and a phone that supports desktop monitoring. For a list of phones that support desktop monitoring, refer the *Cisco Unified CCX Software and Hardware Compatibility Guide*, which is available at:

http://www.cisco.com/en/US/products/sw/custcosw/ps1846/products_device_support_tables_list.html

Design considerations for the new Desktop (Endpoint) Monitoring Service are provided in [Chapter 7, "Bandwidth, Security, and QoS Considerations."](#)

Design Considerations for SPAN-Based Services

The traditional SPAN-based VoIP service allows the IP traffic from one or more ports to be copied and sent to a single destination port.

Be aware of these factors when configuring traditional SPAN-based VoIP monitor services:

- If you are using a second network card in the VoIP monitor, make sure that the network card used by the Cisco Unified CCX Engine has a higher binding order than the one used by VoIP monitor services. Refer the *Cisco CAD Installation Guide* for detailed information about setting network card binding order.
- The following switches do NOT support SPAN sessions: 1700, 2100, 2800, 2948G-L3, 4840G, CE-500, CE-520.
- Local SPANs (LSPANs) are SPANs where all the source ports and the destination port are physically located on the same switch. Remote SPANs (RSPANs) can include source ports that are physically located on another switch. The following switches do NOT support RSPAN (although they may be

an intermediate switch in an RSPAN configuration): 1200, 1900, 2820, 2900, 2900XL, 2926GS, 2926F, 2926T, 2948G, 2950, 2980G, 3000, 3100, 3200, 3500XL, 3524-PWR XL, 3508GL XL, 3550, 5000, 5002, 5500, 5505, 5509

- Some switches do not allow the destination port of a SPAN configuration to act as a normal network connection. The only traffic that can flow through this port is the traffic copied from the SPAN source ports; this requires the computer running the VoIP monitor service to have two network connections (NICs) to function properly. The following switches do NOT support normal network traffic on SPAN destination ports: 2950, 3000, 3100, 3200, 3550
- In some configurations, the VoIP Monitor service can receive duplicate voice packets, which causes poor speech quality. To avoid this, only Ingress packets to a port are sent to the VoIP monitor service. This is a setting for SPAN, which the following switches do NOT support: 1900, 2820, 2900, 2900XL, 3000, 3100, 3200, 3500XL
- In some switches, SPAN cannot use VLANs as sources, which is known as VSPAN. In that case, SPAN must designate individual ports to use for monitoring. The following switches do NOT support VSPAN: 1200, 1900, 2820, 2900XL, 2950, 3000, 3100, 3200, 3500XL, 3524-PWR XL

For more information, refer the *Voice Over IP Monitoring Best Practices Deployment Guide*.

Table B-1 shows the limits of the number of SPAN and RSPAN sessions that can exist on a switch:

Table B-1 SPAN AND RSPAN Switch-Based Session Limits

Switch Model	Maximum SPAN Sessions Allowed
1200	1
1900	1
2820	1
2900	1
2900XL	1
2926GS	5
2926GL	5
2926T	5
2926F	5
2940	1
2948G	5
2950	1
2960 LAN Lite	1
2960 LAN Base	2
2980G	5
3000	1
3100	1
3200	1
3500XL	1
3524-PWR XL	1
3508GL XL	1

Table B-1 SPAN AND RSPAN Switch-Based Session Limits (continued)

Switch Model	Maximum SPAN Sessions Allowed
3550	2
3560	2
3750	2
4003	5
4006	5
2912G	5
5000	5
5002	5
5500	5
5505	5
5509	5
6006	30
6009	30
6506	30
6509	30
6513	30

Deployment Guidelines for Agent Phones that support G.722 or iLBC

Cisco Unified CCX is capable of monitoring and recording G.711 and G.729 agent calls only. The newer version of some agent phones for Cisco Unified CM and Cisco Unified CME support G.722 and iLBC. If both the calling device (voice gateway or IP Phone) and agent phone support G.722 or iLBC, these codecs may be chosen as the preferred codec for the call. Thus, monitoring and recording will fail. In order to prevent these codecs from being used in the call, the following configurations are recommended:

For Cisco Unified CM

- Disable advertising G.722 codec capability for the agent phone if the phone supports this codec.
- In the Region used by the agent phone, set the audio codec as G.711 or G.729 only and do not set the Link Lossy Type as Lossy to prevent iLBC from being used.

For Cisco Unified CME

Do not set the preferred codec as G.722 or iLBC for any device registered with Cisco Unified CME so that these codecs will not be chosen as the result of codec negotiation during call setup.



Cisco Unified Contact Center Express Integration with LDAP Server

Cisco Unified CCX stores the configuration in the local datastore on the Cisco Unified CCX server. Cisco Unified CCX accesses the user information from Cisco Unified CM via the Cisco Unified CM Administrative XML Layer (AXL) API. User authentication is also done via the Cisco Unified CM AXL API.

Cisco Unified CCX supports Microsoft Active Directory (AD) and Netscape Directory (ND). However, since the integration is done on the Cisco Unified CM LDAP configuration, the user information is downloaded from the LDAP directory to the Cisco Unified CM local database, which in turn is synched down to Cisco Unified CCX periodically via the AXL API. User authentication requests are sent to Cisco Unified CM via the AXL API and then relayed to the external LDAP directory service if configured.

Because user authentication requires access to a user database in the LDAP server, if the LDAP server is down or unavailable, you cannot access the Cisco Unified CCX Administration web interface and agents cannot log in. Thus, install a redundant LDAP server to provide high availability. Cisco Unified CM allows you to configure multiple LDAP servers to provide redundancy.

Cisco Unified CCX-specific users for Cisco Unified CM Telephony and RmCm subsystems are now created under the Cisco Unified Communications Manager Application User Group. Thus, these users are under the control of Cisco Unified CM and can be created by Cisco Unified CCX via the AXL API. This allows the Cisco Unified CCX auto provisioning feature to work seamlessly without requiring manual access the LDAP directory configuration tool.

In scenarios where multiple Cisco Unified CCX systems are configured on the same Cisco Unified CM cluster, each Cisco Unified CCX system has visibility to all Resources on the Cisco Unified CM cluster. Any user who has been assigned an ICD extension in Cisco Unified CM will be listed as a Resource in Cisco Unified CCX Administration for each Cisco Unified CCX system. Since a Resource can only be associated with one Cisco Unified CCX system, this requires that the Administrator be aware of which resources are associated with each system. The Administrator can mitigate the confusion by having a unique naming convention for Resources associated with a particular Cisco Unified CCX system.

Since Cisco Unified CCX synchronizes with the Cisco Unified CM database for user information every 10 minutes, a Cisco Unified CM cluster with multiple Cisco Unified CCX systems will take longer to synchronize and generate more traffic that could impact the network and server performance.

For more information about LDAP integration on Cisco Unified CM, refer the *Cisco Unified Communications Solution Reference Network Design (SRND)*.

For more information about directory access and best practices, please refer the directory access and integration topic in *Cisco Unified Communications Solution Reference Network Design (SRND)* at: <http://www.cisco.com/go/designzone>





INDEX

A

- A2Q bid assurance [6-1](#)
- accessing corporate data stores [7-11](#)
- agents
 - service level goal [5-3](#)
 - traffic profile [7-1](#)
- AHT [5-2](#)
- architecture, for Cisco Unified Communications Manager Express (Cisco Unified CME) deployment [3-2](#)
- ASR
 - resource allocation [2-24](#)
 - servers [2-24](#)
- audience for this guide [1-i](#)
- Automatic Call Distribution (ACD) [1-6](#)
- Automatic Speech Recognition (ASR) [2-23](#)
- average handle time (AHT) [5-2](#)

B

- bandwidth
 - by codec [7-5](#)
 - estimating [7-1](#)
 - for desktop applications [7-7](#)
 - for VoIP Monitor Service [7-6](#)
 - IP Phone call usage [7-4](#)
 - per-call packet size requirements [7-4](#)
 - silent monitoring usage [7-2](#)
- Basic ACD [3-5](#)
- BHCA [5-2](#)
- bid assurance, A2Q requirements [6-1](#)
- blocked calls [5-2](#)
- Busy Hour Call Attempts (BHCA) [5-2](#)

C

- CAC [7-13](#)
- call admission control (CAC) [7-13](#)
- call blockage [5-2](#)
- call center sizing
 - considerations [5-1](#)
 - principal steps and design considerations [5-4](#)
- call flow example [2-4](#)
- call recording, disk space requirement [4-8](#)
- Campaign Manager [2-13](#)
- capacity, of Unified CCX [A-1](#)
- Catalyst switches, max SPAN sessions allowed [B-2](#)
- Cisco Agent Desktop [1-14](#)
- Cisco Desktop Services [1-13](#)
- Cisco Interaction Manager [2-16](#)
- Cisco IP IVR [1-i](#)
- Cisco Supervisor Desktop [1-19](#)
- Cisco TelePresence Virtual Agent [2-11](#)
- Cisco Unified CCX
 - deployment model [4-1](#)
 - overview [1-2](#)
 - packaging [1-3](#)
- Cisco Unified CCX clusters, integrating with Unified Communications Manager cluster [4-10](#)
- Cisco Unified CCX Engine, functions [2-6](#)
- Cisco Unified CCX Outbound Preview Dialer (Outbound)
 - availability for each package [1-21](#)
 - features [1-22](#)
 - overview [1-21, 2-13](#)
- Cisco Unified CME
 - deploying with Cisco Unified CCX [4-3](#)
- Cisco Unified CM Telephony subsystem [2-2](#)

- Cisco Unified Communications Manager
 - deploying with Cisco Unified CCX [4-2](#)
 - Cisco Unified Communications Manager cluster,
 - deploying with Unified CCX [4-10](#)
 - Cisco Unified Communications Manager Express (Cisco Unified CME)
 - architecture [3-2](#)
 - Basic ACD [3-5](#)
 - fault tolerance [3-5](#)
 - functionality [3-2](#)
 - monitoring and recording [3-4](#)
 - overview [3-1](#)
 - Cisco Unified Communications Manager Express (Unified CME)
 - call processing [3-3](#)
 - Cisco Unified CCX components for [3-4](#)
 - Cisco Unified Email Interaction Manager (EIM)
 - features [1-23](#)
 - licensed components [1-22](#)
 - overview [1-22](#)
 - Cisco Unified ICME software, integration with Cisco Unified CCX [2-24](#)
 - Cisco Unified Preview Outbound Dialer Express (Outbound)
 - components [2-13](#)
 - deployment guidelines [2-16](#)
 - process for outbound call [2-14](#)
 - scalability [2-15](#)
 - Cisco Unified Preview Outbound Dialer Express (Unified OUTDX)
 - call flow [2-15](#)
 - high availability [2-14](#)
 - Cisco Unified Web Interaction Manager (EIM)
 - overview [1-23](#)
 - Cisco Unified Web Interaction Manager (WIM)
 - features [1-24](#)
 - licensed components [1-23](#)
 - Cisco Unified Wireless IP Phone 7920 [2-9](#)
 - classification of traffic [7-13](#)
 - codec
 - G.711 [7-4](#)
 - G.729 [7-4](#)
 - cold standby [2-30](#)
 - Committed Access Rate (CAR) [7-13](#)
 - compatibility [2-31](#)
 - Computer Telephony Integration (CTI) [1-12](#)
 - Config Datastore (CDS) [2-13](#)
 - Configuration and Ordering Tool [5-5](#)
 - contact center, representation [7-3](#)
 - corporate data stores [7-11](#)
 - CSD Record Viewer [2-8](#)
 - CTI Server [2-13](#)
-
- D**
- database redundancy [2-28](#)
 - data store access [7-11](#)
 - data stores
 - agent [2-6](#)
 - configuration [2-6](#)
 - historical [2-6](#)
 - repository [2-6](#)
 - deploying Cisco Unified CCX, guidelines [4-5](#)
 - deployment model
 - Cisco Unified CME [4-3](#)
 - design considerations [4-8](#)
 - overview [4-1](#)
 - Single-Server Non-High Availability Deployment Model—Cisco Unified Communications Manager Integration [4-6](#)
 - Single-Server Non-High Availability Deployment Model—Unified Communications Manager Express Integration [4-7](#)
 - Two-Server High Availability Deployment Model—Unified Communications Manager Integration [4-6](#)
 - with Cisco Unified Communications Manager [4-2](#)
 - desktops
 - Cisco Agent Desktop [2-5](#)
 - Cisco Supervisor Desktop [2-5](#)

destination ports, SPAN configuration [B-2](#)

Dialer [2-13](#)

directories

DC [2-3](#)

Microsoft Active Directory [2-3](#)

Netscape iPlanet [2-3](#)

directory services, Netscape Directory [C-1](#)

disaster recovery [2-30](#)

disk space use [4-8](#)

DNS lookups [7-12](#)

DSCP markings [7-13](#)

E

end-to-end queuing [7-13](#)

Erlang calculators [5-3, 5-5](#)

examples

Sizing Unified CCX Standard Application with 25 Agents [5-5](#)

Standard Resource Calculator Basic Example [5-6](#)

Standard Resource Calculator Call Treatment Example [5-8](#)

F

fault tolerance [2-27](#)

Cisco Unified CCX Engine [2-27](#)

Cisco Unified Communications Manager Express (Cisco Unified CME) [3-5](#)

G

grade of service [5-2](#)

H

high availability [2-27, 2-29, 2-30, 4-8](#)

Historical Reporting [1-12](#)

historical reports [2-5](#)

I

Inbound Voice

components [1-6](#)

licensed components [1-5](#)

overview [1-4](#)

interactive voice response (IVR) [1-9](#)

interfaces [7-13](#)

IPPA [1-18](#)

IP Phone Agent (IPPA)

SPAN port server [2-8](#)

IVR

average port usage time [5-2](#)

ports [5-2, 5-5](#)

sizing ports [5-5](#)

IVR ports [1-5](#)

J

JTAPI

user [2-3](#)

L

LSPAN [B-1](#)

M

managing the Unified CCX system [2-5](#)

Media Resource Control Protocol (MRCP) [2-23](#)

monitoring

desktop [2-7](#)

monitoring and recording [3-4](#)

monitoring and recording redundancy [2-29](#)

Monitoring Server [2-6](#)

N

NAT [7-12](#)

Network Address Translation (NAT) [7-12](#)

NIC

on VoIP monitor server [B-2](#)

processing packets [2-7](#)

O

OOB (Odysoft ODBC Collector) Service [2-23](#)

P

packaging, of Cisco Unified CCX. [1-3](#)

percent blockage [5-2](#)

performance criteria

categories [6-2](#)

effects of [6-3](#)

Ping, used by CAD [7-12](#)

Policy Based Routing (PBR) [7-13](#)

Port Address Translation (PAT) [7-12](#)

ports

gateway [5-2](#)

interfaces [7-13](#)

IVR [5-2](#)

protocols [7-13](#)

PSTN [5-2](#)

queue [5-2](#)

sizing [5-5](#)

utilization [7-12](#)

preliminary information [5-2](#)

protocols [7-13](#)

provisioning

(*See* sizing)

PSTN [5-2](#)

Q

QoS

and Call Admission Control [7-13](#)

classifications for Unified CCX interfaces [7-13](#)

considerations for CAD [7-14](#)

Quality Management

features [1-25](#)

licensed components [1-25](#)

overview [1-24](#)

Quality Management Recorded Contact Storage Calculation [2-23](#)

Quality of Service

See QoS

Quality of Service (QoS) [7-13](#)

queue ports [5-2](#)

R

real-time reports [2-5](#)

Recording Server [2-7](#)

redundancy

database [2-28](#)

monitoring and recording [2-29](#)

overview [2-27](#)

remote agent [7-1](#)

Remote Agent Over Broadband [2-11](#)

Remote Agent Traffic Profile [7-1](#)

remote supervisory monitoring [2-9](#)

reports

historical [2-5](#)

real-time [2-5](#)

Resource Manager [2-13](#)

resource requirements [5-5](#)

RSPAN [B-1](#)

RTP streams [2-8](#)

S

scope of this guide [1-i](#)

security [7-11](#)

servers

- sizing [6-1](#)

serviceability [7-11](#)

service level [5-2](#)

Session Initiation Protocol (SIP) [2-10](#)

silent monitoring

- bandwidth usage [7-2](#)
- providers [7-2](#)
- requestors [7-2](#)

Single-Server Non-High Availability Deployment Model—Cisco Unified Communications Manager Integration [4-6](#)

Single-Server Non-High Availability Deployment Model—Unified Communications Manager Express Integration [4-7](#)

SIP phones [2-10](#)

sizing

- call center [5-1](#)
- Configuration and Ordering Tool [5-5](#)
- document [5-2](#)
- example calculations [5-5](#)
- IVR ports [5-5](#)
- servers [6-1](#)
- Unified CCX server [6-1](#)

sizing tools

- Configuration and Ordering Tool [6-1](#)
- descriptions [6-1](#)

software components

- Cisco Unified CCX Engine [2-6](#)
- Database [2-6](#)
- Monitoring [2-6](#)
- overview [2-6](#)
- Recording [2-6](#)

source ports, SPAN configuration [B-2](#)

SPAN [B-1](#)

- port monitor server [2-8](#)

T

TCP ports [7-13](#)

terminology [5-1](#)

Text-to-Speech (TTS) [2-23](#)

traffic classification [7-13](#)

Traffic Shaping [7-13](#)

TTS

- resources [2-24](#)

Two-Server High Availability Deployment Model—Unified Communications Manager Integration [4-6](#)

U

Unified CCX

- capacity [A-1](#)
- Configuration and Ordering Tool [5-5](#)
- interfaces [7-13](#)
- protocols [7-13](#)
- sizing the server [6-1](#)

Unified CCX Gateway PG [2-24](#)

Unified CM

- sizing tool [6-2](#)
- system performance [6-3](#)

Unified CM Telephony trigger [2-2](#)

V

Voice over IP monitoring [B-1](#)

VSPAN [B-2](#)

W

Wireless Access Point (WAP) [2-9](#)

Workforce Management

- features [1-26](#)
- licensed components [1-26](#)
- overview [1-26](#)

